

G100-1L/G300-1L/G600-1L Industrial Peristaltic Pump Operating Manual



LONGER

Baoding Longer Precision Pump Co., Ltd.

Add: 3rd/4th Floor, Building 6B, University Science Park
Baoding National, High - Tech Industrial Development Zone
Baoding, Hebei, China 071051
Tel: 86 - 312 - 3110087 3138553
Fax: 86 - 312 - 3168553
E - mail: longer@longerpump.com
[Http://www.longerpump.com](http://www.longerpump.com)

2024.6

Industrial Peristaltic Pump GX00-1L

Baoding Longer Precision Pump Co.,Ltd.

A **Halma** company

Contents

1. General Information	1
1.1 Precautions	1
1.2 Repair Notes	1
1.3 Contacts Information	2
2. Product Introduction	2
2.1 Main Features	2
2.2 Unpacking	3
2.3 System Structure and Dimensions	3
2.4 Applicable Pump Head and Tubing	5
2.5 System Installation	7
2.5.1 Pump Head Installation	7
2.5.2 Mounting of G100-1L/G300-1L/G600-1L	11
2.5.3 Grounding of G100-1L/G300-1L/G600-1L	12
2.6 Technical Specifications	14
2.6.1 Work Mode Introduction	14
2.6.2 Control Mode Introduction	15
3. System Operation	17
3.1 Keypad and Display	17
3.1.1 Keypad Functions	17
3.1.2 Display Description	20
3.2 Screens and Parameter Setting	21
3.2.1 Diagram of the Screen Changing Logic	21
3.2.2 Run Screens	22
3.2.3 Parameter Setting by Keypad	25
3.3 Flow Rate Calibration	37
3.3.1 Flow Rate Calibration in Keypad Control Mode	37
3.3.2 Flow Rate Calibration in Communication Control Mode	40
4. Definition of the External Control Interface	40
5. Appendix	41
Appendix 1: Parameter Default Setting	41
Appendix 2: Modbus RTU Protocol	43
Appendix 3: Longer Pump OEM Communication Protocol	47
Appendix 4: Alarm Display	55

1. General Information

1.1 Precautions

- The housing of the pump drive is equipped with a grounding terminal, in order to ensure the safety of the operator and improve the electromagnetic compatibility of the equipment, please reliably ground this product.
- The pump drive has high precision and high IP rating. Please do not disassemble, refit or maintain the product without permission, so as to avoid any damage or deterioration to its performance.
- All ports at the end of the drive shall be protected against damp and water. Besides, the end caps or plugs shall be screwed up in time.
- If tubing leaks or bursts, fluid may spray from the tubing and pump head. Take reasonable practicable measures to ensure the operator's safety.
- Make sure fluid in the tubing has been drained out, no pressure in the pipeline and disconnect pump from mains power, while removing or replacing the tubing.
- Disconnect the pump from the mains power before connecting the control signal wire.
- Do not touch the rotor while pump is running.
- Release the compression block when pump stop running for a long time to avoid tubing deformation caused by squeezing.
- Keep the rotor clean and dry to avoid tubing excessive wear and premature failure of pump head or drive.
- Please do not add the lubricating oil to the rotor by yourself, any improper operation could corrode the pump head housing or dislocate the tubing.
- Please connect the power cord, control cable, communication cable in correct way, and do not damage the plug.
- If the pump head can't resist organic solvent and corrosive liquid, please clean the liquid left on the surface of the pump head immediately

1.2 Repair Notes

Please contact Longer Pump or its distributor, and provide the product serial number before returning the product. Products which has been

contaminated with, or exposed to, toxic chemicals or any other substance hazardous to health must be decontaminated before returning to Longer Pump or its distributor. Ship the product in its original packaging or better, to against possible damage or loss during the transport.

1.3 Contacts Information

Baoding Longer Precision Pump Co., Ltd
3rd Floor, Building 6B, University Science Park Baoding National, High -
Tech Industrial Development Zone, Baoding, Hebei, China 071051
Email: longer@longerpump.com
Tel: [86-312-3110087](tel:86-312-3110087)
Fax: [86-312-3168553](tel:86-312-3168553)
www.longerpump.com

2. Product Introduction

The Gx00-1L series is an industrial peristaltic pump drive specially developed for severe industrial applications. It is small and simple in shape and features a compact structure. With good electromagnetic compatibility, the pump will not fail in the EMI environment and will not interfere with other electronic equipment nearby. It also has high IP rating (IP66), which is suitable for wet and dusty environment. In addition, it has aluminum alloy housing with good heat dissipation performance, and the anti-corrosion paint treatment improves the corrosion-resistant performance. The pump drives are compatible with many Longer Pump peristaltic pump heads and accepts many different tubings. G100-1L can provide a max flow rate of 750mL/min (single channel), G300-1L can provide a max flow rate of 1.75L/min (single channel), G600-1L can provide a max flow rate of 3.25L/min.

2.1 Main Features

The main functions of Gx00-1L series products are as follows:

- Support multiple work modes: continuous transfer, timed transfer, volume transfer, prime transfer at full speed

- Calibration function: calibrate the flow rate through input actual flow rate or pumped volume
- LCD can display a variety of parameters: pump speed, flow rate, running time and pumped volume can be displayed on different screens.
- Support three control modes: keypad control, RS485 communication control, and external signal control.

2.2 Unpacking

- (1) Take out the pump and accessories from the shipping carton.
- (2) Check the packing list and confirm that the attachments are intact and complete.
- (3) In case of any questions, please contact Longer Pump or local distributor.

2.3 System Structure and Dimensions

The Gx00-1L series peristaltic pump includes the following parts:

- ① Pump Drive
- ② Pump Head + Tubing

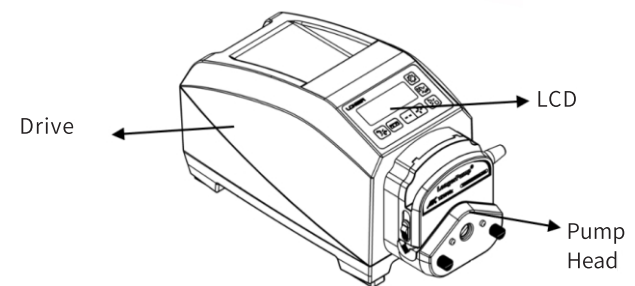

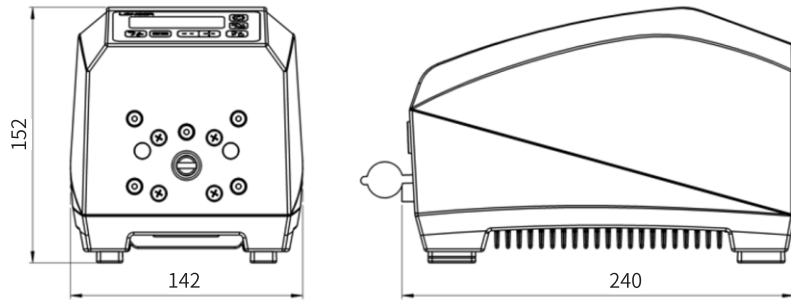
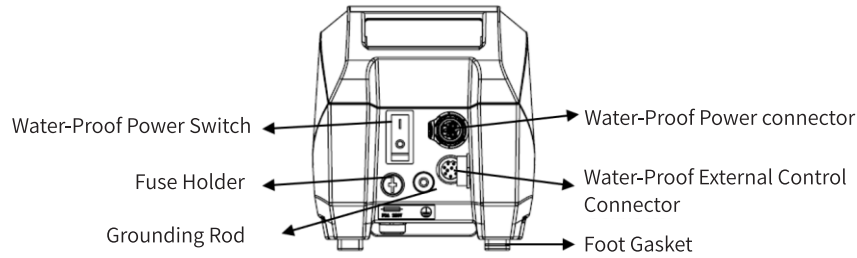

Outline Dimension

Fuse: F2A 250V

2.4 Applicable Pump Head and Tubing

Pump Drive Model	Pump Head	Applicable Silicone Tubing	Applicable Pharmed Tubing	Max Flow Rate Reference mL/min	
G100-1L	YZ1515x, YZ II 15	13#, 14#, 19#, 16#, 25#, 17#, 18#	13#, 14#, 19#, 16#, 25#, 17#, 18#	570	
	FG15-13	13#, 14#, 19#, 16#, 25#, 17#, 18#	13#, 14#, 19#, 16#	645	
	DMD15-13-B	2*13#, 2*14#, 2*19#, 2*16#, 2*25#	2*13#, 2*14#, 2*19#, 2*16#	560	
	YZ2515x	15#, 24#	Not recommended	400	
	YZ II 25	15#, 24#, 35#, 36#	Not recommended	750	
	FG25	15#, 24#	Not recommended	480	
	BZ15-13-A	14#	14#	33	
	BZ15-13-B	16#	16#	120	
	BZ15-13-C	25#	25#	225	
	BZ15-13-D	17#	17#	400	
G100-1L	BZ25-13-B	24#	Not recommended	375	
	DG15-24	16#, 25#, 17#	Not recommended	450 (single channel)	
	DG15-28	13#, 14#, ID≤3.17mm, wall thickness 0.8-1mm	ID≤3.17mm Wall thickness: 0.8-1mm	72 (single channel, pump speed ≤100rpm)	
	DG-1-A (C)	ID≤3.17mm Wall thickness: 0.8-1mm	ID≤3.17mm Wall thickness: 0.8-1mm	48 (single channel, pump speed ≤100rpm)	
	DG-2-A (C)	ID≤3.17mm Wall thickness: 0.8-1mm	ID≤3.17mm Wall thickness: 0.8-1mm		
	DG-4-A (C)	ID≤3.17mm Wall thickness: 0.8-1mm	Not recommended		
	DG-6-A (C)	ID≤3.17mm Wall thickness: 0.8-1mm	Not recommended		
	DG-8-A (C)	ID≤3.17mm Wall thickness: 0.8-1mm	Not recommended		
	DG-1-B (D)	ID≤3.17mm Wall thickness: 0.8-1mm	ID ≤3.17mm Wall thickness: 0.8-1mm	32 (single channel, pump speed ≤100rpm)	
	DG-2-B (D)	ID≤3.17mm Wall thickness: 0.8-1mm	ID≤3.17mm Wall thickness: 0.8-1mm		
	DG-4-B (D)	ID≤3.17mm Wall thickness: 0.8-1mm	Not recommended		
	dPOFLEX BPH01		13#, 14#, 19#, 16#, 25#		130

Pump Drive Model	Pump Head	Applicable Silicone Tubing	Applicable Pharmed Tubing	Max Flow Rate Reference mL/min
G300-1L	YZ1515x, YZ II 15	13#, 14#, 19#, 16#, 25#, 17#, 18#	13#, 14#, 19#, 16#, 25#, 17#, 18#	1280
	FG15-13	13#, 14#, 19#, 16#, 25#, 17#, 18#	13#, 14#, 19#, 16#	1400
	DMD15-13-B	2*13#, 2*14#, 2*19#, 2*16#, 2*25#	2*13#, 2*14#, 2*19#, 2*16#	1200
	YZ2515x	15#, 24#	Not recommended	930
	YZ II 25	15#, 24#, 35#, 36#	Not recommended	1750
	FG25-13	15#, 24#	Not recommended	1280
	BZ15-13-A	14#	14#	88
	BZ15-13-B	16#	16#	265
	BZ15-13-C	25#	25#	560
	BZ15-13-D	17#	17#	930
	BZ25-13-B	24#	Not recommended	930
	DG15-24	16#, 25#, 17#	Not recommended	1050 (Single Channel)
	BPH01	13#, 14#, 19#, 16#, 25#	13#, 14#, 19#, 16#, 25#	300

	BZ15-13-D	17#	17#	1730
	BZ25-13-B	24#	Not recommended	1730
	DG15-24	16#, 25#, 17#	Not recommended	1900
	BPH01 (intermittent when speed>400rpm)	13#, 14#, 19#, 16#, 25#	13#, 14#, 19#, 16#, 25#	530 (@600rpm)

2.5 System Installation

2.5.1 Pump Head Installation

(1) Installation of Pump Head YZ1515x/YZ2515x/YZII15/YZII25

Insert the tang of the pump head shaft into the slot of the motor shaft, and align the two mounting holes on the pump head with the mounting holes on the pump drive. Then insert the two mounting screws into the mounting holes and tighten the screws.



(2) Installation of Pump Head FG15-13/FG25-13

Mount the pump head:

Mount the mounting plate on the drive unit by tightening three mounting screws M4X10. Insert the tang of the pump head shaft into the slot of the motor shaft, turn the pump head 45 degrees relative to the vertical direction, engage the bayonet on the mounting plate with the bayonet slot on the back of the pump head, turn the pump head clockwise until it locks into an upright position.

Pump Drive Model	Pump Head	Applicable Silicone Tubing	Applicable Pharmed Tubing	Max Flow Rate Reference mL/min
G600-1L	YZ1515x, YZ II 15	13#, 14#, 19#, 16#, 25#, 17#, 18#	13#, 14#, 19#, 16#, 25#, 17#, 18#	2380
	FG15-13	13#, 14#, 19#, 16#, 25#, 17#, 18#	13#, 14#, 19#, 16#	2600
	DMD15-13-B	2*13#, 2*14#, 2*19#, 2*16#, 2*25#	2*13#, 2*14#, 2*19#, 2*16#	2500
	YZ2515x	15#, 24#	Not recommended	1730
	YZ II 25	15#, 24#, 35#, 36#	Not recommended	3250
	FG25-13	15#, 24#	Not recommended	2380
	BZ15-13-A	14#	14#	160
	BZ15-13-B	16#	16#	490
	BZ15-13-C	25#	25#	1040

LONGER Instructions for use of peristaltic pump

Remove the pump head:
Push the locking lever back and turn the pump head anti-clockwise about 45 degrees. Then take off the pump head from the mounting plate.



(3) Installation of Pump Head DMD15-13 and Tubing

Mount the pump head:
Mount the mounting plate on the drive unit through three cross recess head screws M4X10. Release the two levers to open the pump head and remove the compression block. Insert the tang of the pump head shaft into the slot of the motor shaft. Press the pump head firmly against the mounting plate. Turn the pump head to align the mounting holes on the pump head with the mounting holes on the mounting plate. Insert the two mounting screws (hexagon socket head cap screw M3X8) into the mounting holes and tighten the screws.

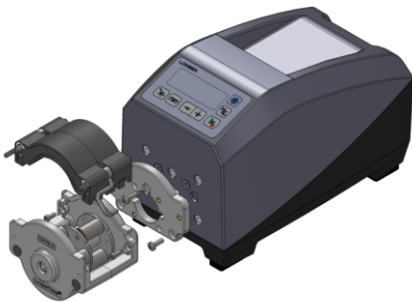

LONGER Instructions for use of peristaltic pump



Load the tubing:
Release the levers to remove the compression block. Insert the tubing fitting assembly into the compression block.
Note: When using 25# tubing, move the partition blocks to the outermost positioning hole.

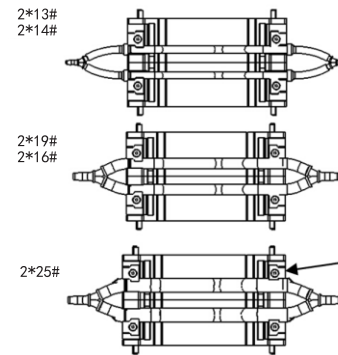

The four partition blocks need to be fixed at the outermost positioning holes

Put the compression block with tubing fitting assembly back to the pump head, and lock the levers.

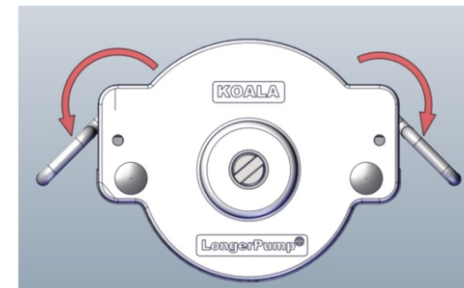

(4) Installation of Pump Head BZ15/BZ25

Insert the tang of the pump head shaft into the slot of the motor shaft, and align the four mounting holes on the pump head with the mounting holes on the pump drive. Then insert the four mounting screws into the mounting holes and tighten the screws.

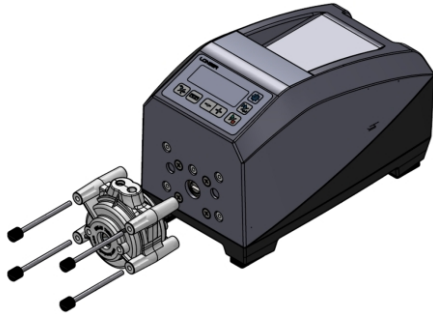

(5) Installation of Pump Head DG15-24/DG15-28

Mount the mounting plate on the drive unit through four screws M4X10. Remove the tubing and the pump head cartridges. Insert the tang of the pump head shaft into the slot of the motor shaft. Press the pump head firmly against the pump drive. Turn the pump head to align the mounting holes on the pump head with the mounting holes on the pump drive. Insert the screws M4X16 and tighten the screws.

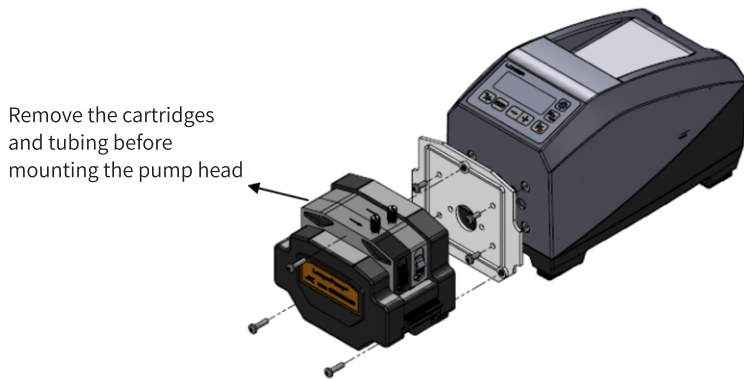

(6) Installation of Pump Head DG Series

Remove the tubing and the pump head cartridges. Insert the tang of the pump head shaft into the slot of the motor shaft. Press the pump head firmly against the pump drive. Turn the pump head to align the mounting holes on the pump head with the mounting holes on the pump drive. Insert the 2 hexagon socket head cap screws M4X8 and tighten the screws.

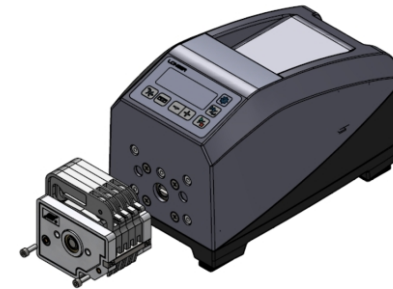

2.5.2 Mounting of G100-1L/G300-1L/G600-1L

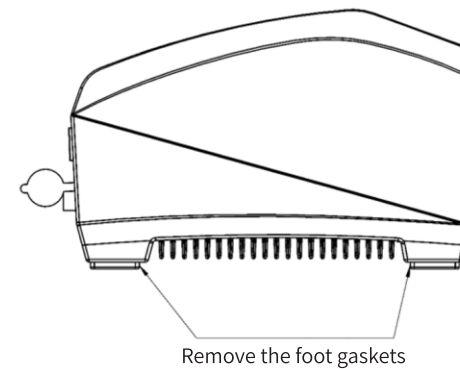

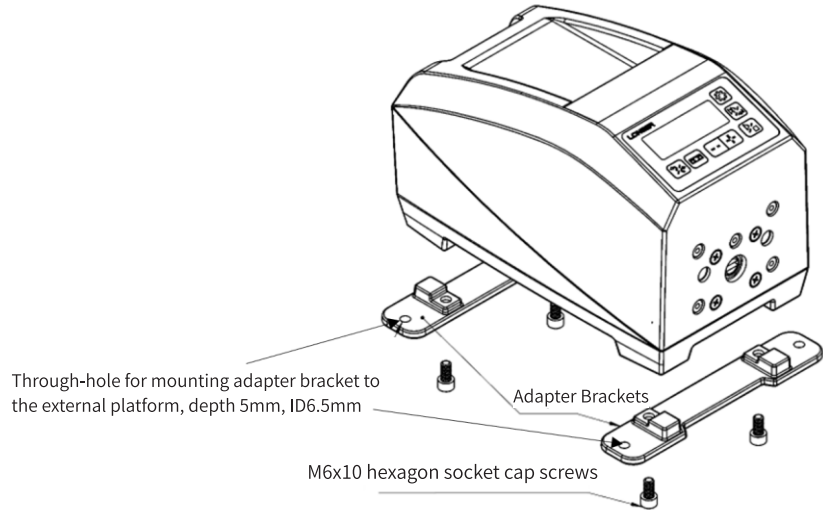

Note: The adapter bracket is an optional accessory.

2.5.3 Grounding of G100-1L/G300-1L/G600-1L

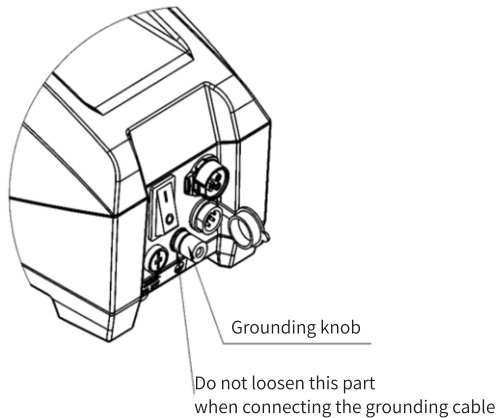

G100-1L, G300-1L and G600-1L are all equipped with grounding rod. Reliable grounding of the pump will prevent the misoperation and damage from electromagnetic interference.

Grounding steps:

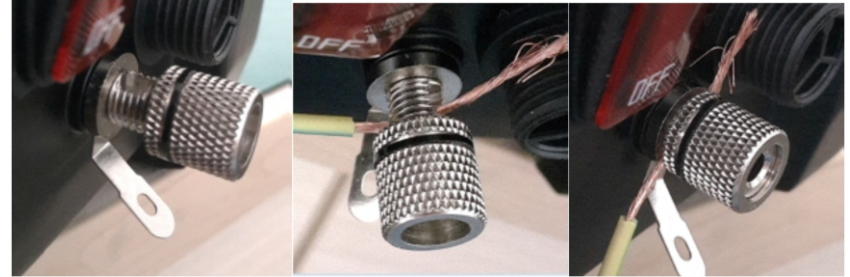

Or directly solder the grounding cable on the grounding rod.



2.6 Technical Specifications

Pump model	G100-1L	G300-1L	G600-1L
Speed range	0, 0.01-150 (rpm), CW/CCW	0, 0.01-350 (rpm), CW/CCW	0, 0.01-650 (rpm), CW/CCW
Speed resolution	0.01rpm (<10rpm) 0.1rpm (10rpm≤speed<100rpm) 1rpm (100rpm≤speed≤Max speed)		
Flow rate range	0.15uL/min-750mL/min	0.15uL/min-1750mL/min	0.15uL/min-3250mL/min
Display	LCD for speed, flow rate, running time, pumped volume, and other setting parameters		
Work mode	Continuous transfer, timed transfer, volume transfer		
Calibration	Improve the flow rate and dispensing volume accuracy		
Control mode	Keypad control (start/stop can be controlled by a footswitch), external signal control and communication control		
External control	Start/stop control, direction control: logic level signal or switch signal (dry contact), momentary or maintained trigger mode can be configured Speed control: 0-5V, 0-10V, 4-20mA, 0-10kHz signal to control the pump speed External control parameters can be configured through keypad (signal type, trigger mode, max speed), and communication commands (signal type, trigger mode and speed/signal range).		
Communication control	RS485 interface, Modbus RTU and Longer Pump OEM protocol, communication control parameters can be configured through keypad and communication commands		
Keypad lock	Keypad can be locked to prevent misoperation, the delay time (5s to 1min) before lock can be configured		
Parameter memory	Running parameters and system parameters can be saved automatically (it takes 1 second to save the parameters)		
Pump status when powered up	The pump status when powered up can be set to stop or the same status before power-off		
Prime	Fast filling or emptying at full speed		
Certificate	CE, UKCA EMC: EN IEC61000-6-2:2019 EN IEC61000-6-4:2019 LVD: EN 61010-1:2010/A1:2019 EN 61010-1:2010/A1:2019		
Dimension (LxWxH)	240*142*152(mm)		
Power supply	AC100-240V 50Hz/60Hz		
Power consumption	25W	40W	60W
Working condition	Environment temperature: 0°C~40°C, relative humidity: 10%~90%		
IP rating	IP66		
Weight	3.64kg	3.75kg	3.75kg

2.6.1 Work Mode Introduction

Gx00-1L series pump can work in different work modes: continuous transfer mode, timed transfer mode and volume transfer mode.

Continuous transfer mode: the pump will run continuously and will stop when receiving a stop signal from the keypad, external signal or communication command.

Timed transfer mode: set the target time before starting the pump, the pump will begin timing when starts running, and the pump will stop automatically when the target time is reached.

Volume transfer mode: set the target volume before starting the pump, the pump will begin timing when starts running, and the pump will stop automatically when the target volume is reached. (volume = flow rate * time). Before working in the volume transfer mode, the flow rate should be calibrated so that the actual pumped volume can match the target volume.

2.6.2 Control Mode Introduction

There are three control modes: keypad control, external signal control, communication control. Refer to Chapter 3.3.3 for control mode setting details.

- (1) Keypad control mode (INT):** set all the parameters and control the pump running through the keypad.
In the keypad control mode, the start/stop of the pump can also be controlled by a logic level signal, a switch signal (dry contact signal), or a footswitch. Refer to Chapter 3.3.3 for the start/stop trigger mode setting details.

Note:

- The keypad control mode can only be set through the keypad.
 - In the keypad control mode, the Start/stop key, a footswitch, or other external start/stop signal are all valid.
- (2) External signal control mode (EXT):** control the start/stop status, running direction and pump speed by external signals.

Before controlling the pump with external signals, the parameters of speed signal type, max speed corresponding to max speed signal, start/stop trigger mode, and run direction trigger mode should be set through the keypad or communication command. Refer to Chapter 3.3.3 for parameter setting by keypad. Refer to Appendix B for parameter setting by command. Refer to Chapter 4 for the signal requirement and wiring instructions.

Pump speed: can be controlled by 0-5V, 0-10V, 4-20mA, 0-10kHz signal, and max speed corresponding to the max signal can be set. The input speed signal should be the same as the signal type setting. when the pump is working in the external signal control mode, tap Enter Key to check the current speed signal setting.

Start/stop: can be controlled by a logic level signal (5V-24V) or a switch signal (dry contact signal). The trigger mode can be set to pulse trigger (maintained) or level trigger (momentary).

Running direction: can be controlled by a logic level signal (5V-24V) or a switch signal (dry contact signal). The trigger mode can be set to pulse trigger (maintained) or level trigger (momentary).

Note:

1. The external control mode only can be set through the keypad.
2. In the external signal control mode, the start/stop and running direction can not be controlled through the keypad. But press and hold the Start/stop key, the pump will stop.
3. In the external signal control mode, the timed transfer work mode and volume transfer work mode are invalid.
- (3) **Communication control mode (COM):** set all parameters and control the pump running through RS485 interface and communication commands. (Both Modbus RTU and Longer Pump OEM protocol are supported.)

Before controlling the pump with communication commands, the parameters of pump address, baud rate and parity should be set through the keypad or communication command. Refer to Chapter 3.3.3 for parameter setting by keypad. Refer to Appendix B for parameter setting by command. Refer to Chapter 4 for the wiring instructions.

Note:

1. The communication control mode can be set through the keypad or communication command.
2. In the communication control mode, the start/stop and running direction can not be controlled through the keypad. But press and hold the Start/stop key, the pump will stop.

3. Communication control has the highest priority. When the pump is working in keypad control or external signal control mode, send the communication control enable command, the pump will stop running and change to communication control mode.
4. In the communication control mode, the flow rate can be calibrated by send the actual pumped volume or actual flow rate value. But the calibration screen will not be displayed on the screen.



3. System Operation

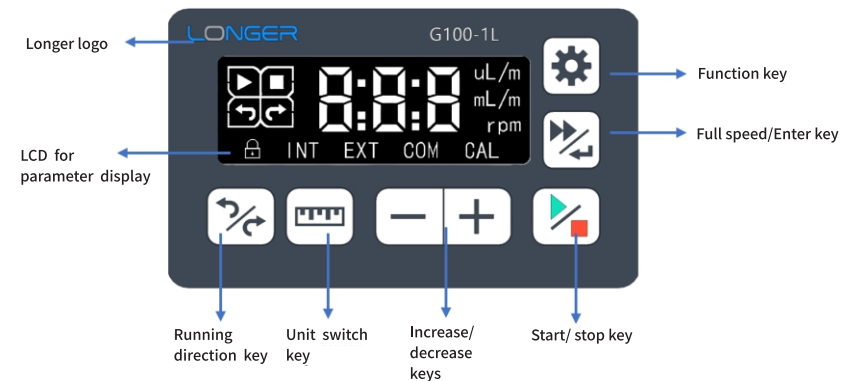

3.1 Keypad and Display



3.1.1 Keypad Functions

Key	Functions	Remark
 Running direction key	In the keypad control mode, when the pump is on standby with a running screen or is working in the continuous transfer mode, tap this key to switch the running direction.	The key is invalid in the external signal control mode, communication control mode, timed transfer mode, volumed transfer mode, calibration process, and parameter setting screen.

Key	Functions	Remark
 Unit switch key	<ol style="list-style-type: none"> 1. Change the decimal point position: when the pump is on standby with a running screen, tap the unit switch key to change the decimal point position and units of the pump speed, flow rate, and dispensing volume. 2. Change the calibration variable: when the pump displays the calibration screen, press and hold this key to switch the variable between flow rate (input the actual flow rate to calibrate) and volume (input the actual pumped volume to calibrate). 	
 Increase and decrease keys	<ol style="list-style-type: none"> 1. Set the value: when the pump displays a running screen, tap the key "+" or "-" to increase or decrease the lowest digit of the displayed value. Press and hold the keys to quickly increase or decrease the displayed value. 2. Change the parameter options: when the pump displays the parameter setting screen, tap the key "+" or "-" to change the parameter options. 	When the pump is running, the "+" and "-" keys are only valid to change the pump speed and flow rate.
 Start/ stop key	<ol style="list-style-type: none"> 1. In the keypad control mode: when the pump displays a running screen, tap the key to start or stop the pump. 2. In the external control mode and communication control mode, when the pump is running, press and hold the start/stop key to stop the pump. The control mode will not be changed. 	In the keypad control mode, when the pump is connected to a footswitch or other external start/stop signal, the Start/stop key is still valid.

 Full speed/Enter key	<ol style="list-style-type: none"> 1. Full speed: In the keypad control mode, when the pump displays a running screen, press and hold the Full speed key to run the pump at full speed, and release the key to return to the previous status. 2. Confirm the parameter: when the pump displays the parameter setting screen, tap the Enter key to confirm the setting value and proceed to the next parameter setting screen. 3. Pump calibration: when the pump displays the calibration screen, tap the Enter key to calibrate the pump according to the displayed flow rate or volume. 	<ol style="list-style-type: none"> 1. Full speed function is invalid in timed transfer mode, volumed transfer mode and calibration process. 2. The setting parameters in the parameter screen will be invalid without tapping the Enter key.
 Function key	<ol style="list-style-type: none"> 1. Change the running screen: when the pump displays the running screen, tap Function key to change the running screen. When the pump displays the parameter setting screen, tap Function key to cancel current parameter setting and return to previous parameter setting screen. 2. Enter/exit the parameter setting screen: press and hold the Function key to enter or exit the parameter setting screen. The first parameter setting screen is the control mode setting screen. Exit action can be done when pump displays any parameter setting screen. And this function is valid in any control mode. 3. Unlock the keypad: when the keypad is locked, press and hold the Function key to unlock the keypad. 	

3.1.2 Display Description

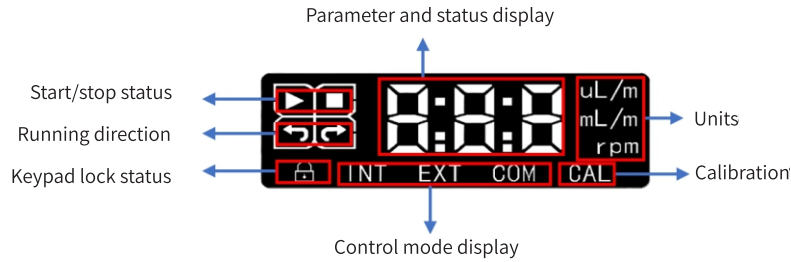

Icon	Name	Description	Remark
	Run	This icon is displayed on the running screen when the pump is running	
	Stop	This icon is displayed on the running screen when the pump is stopped	
	Counter-clockwise	This icon is displayed on the running screen when the pump is running counter-clockwise.	
	Clockwise	This icon is displayed on the running screen when the pump is running clockwise.	
	Keypad lock	This icon appears on the running screen when the keypad lock is locked	The keypad lock function can be enabled in the parameter setting screen, and the delay time (5s to 1min) before lock can be set.
	Keypad control mode	This icon is displayed on the running screen when the current control mode is keypad control.	
	External control mode	This icon is displayed on the running screen when the current control mode is external control.	
	Communication control mode	This icon is displayed on the running screen when the current control mode is communication control.	
	Calibration	This icon on the running screen indicates that the flow rate can be calibrated on the current screen.	
	Parameter and status display	This area displays pump system parameters, running parameters and pump status.	
	Parameter and status display	, and indicate the current value is volume. means uL/min. means mL/min. means L/min. , and indicate the current value is flow rate.	
	Unit for pump speed	This icon on the running screen indicates that the current value is pump speed.	

3.2 Screens and Parameter Setting

3.2.1 Diagram of the Screen Changing Logic

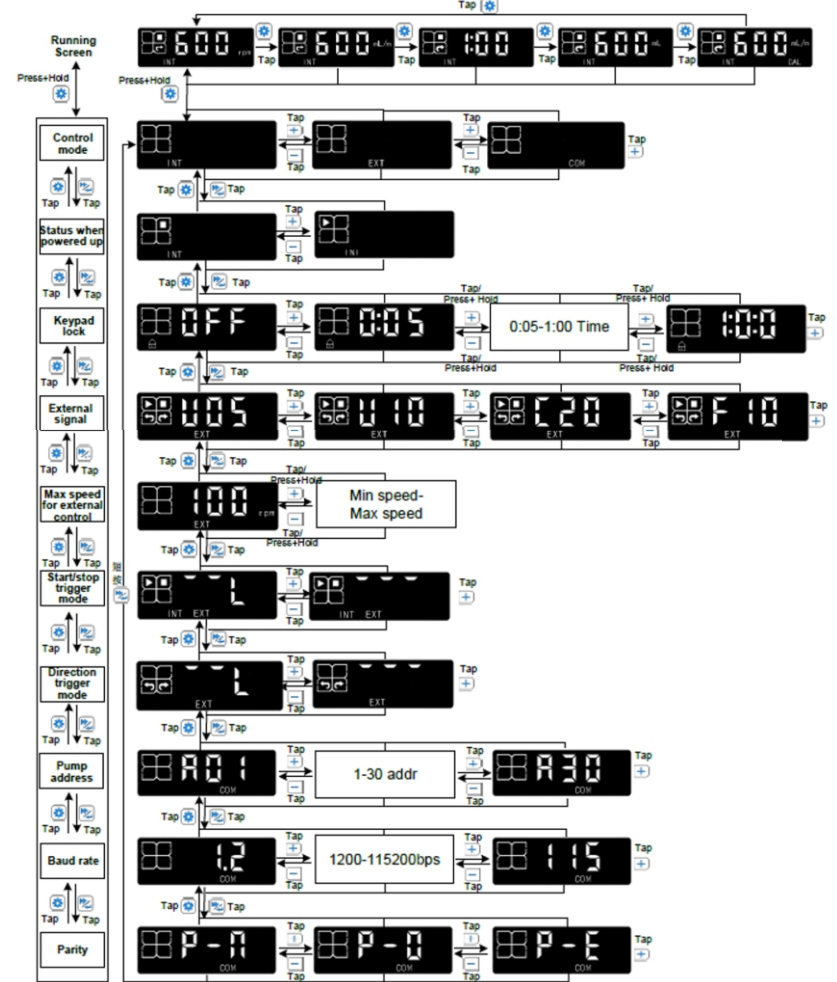







3.2.2 Run Screens

Gx00-1L series pump can work in different work modes: continuous transfer mode, timed transfer mode and volume transfer mode. When the pump is running, the pump speed, flow rate, time and volume can be displayed on the screen. 5 run screens can be displayed on the LCD to indicate the pump running status. Tap the Function key  to switch the screens. The pump can start running when displaying any run screen.



Run Screen	Display Example	Description
Pump Speed Screen	 <p>The information displayed: Keypad control mode, pump speed 600rpm, stop status, clockwise direction</p>	<ul style="list-style-type: none"> On the Pump Speed Screen, the displayed unit is rpm, indicating the three-digit number on the screen represents the pump speed. The screen also shows the start/stop status, the running direction and the control mode. When the pump is powered on for the first time, the screen will display the pump speed screen by default. The pump speed can be adjusted when the pump is running or on standby. The pump speed and flow rate correspond to each other. One value will be automatically changed as the other is adjusted. After calibration is completed, the pump speed will adjust to match the set flow rate. If the calibrated pump speed exceeds the max speed, the pump speed will adjust to the max speed, and the flow rate will change to the max flow rate at the max speed.

Run Screen	Display Example	Description
Flow Rate Screen	 <p>The information displayed: Keypad control mode, pump speed 600rpm, stop status, clockwise direction</p>	<ul style="list-style-type: none"> On the Flow Rate Screen, the displayed unit is uL/m, mL/m or L/m, indicating the three-digit number on the screen represents the flow rate. The screen also shows the start/stop status, the running direction and the control mode. The flow rate can be adjusted when the pump is running or on standby. The pump speed and flow rate correspond to each other. One value will be automatically changed as the other is adjusted. The flow rate should be calibrated when running the pump for the first time, after replacing the pump head, or after replacing the tubing. So that the displayed flow rate will match the actual flow rate.
Time Screen	 <p>The information displayed: Keypad control mode, set the target time to 1 minute, stop status, clockwise direction</p>	<ul style="list-style-type: none"> On the Time Screen, the displayed three-digit number represents time. The screen also shows the start/stop status, the running direction and the control mode. When the pump is on standby, the time can be set from 0 seconds to 999 minutes. When the time is set as 0s, the pump will run in continuous transfer mode. When the time is set to other values, the pump will run in timed transfer mode. When the pump starts running, it will begin timing. The screen will show the elapsed running time. When the preset target time is reached, the pump will automatically stop. If the time is set to 0s, and the pump running time exceeds the max display value of 999min, the displayed time will start again from 0s. 1:00 means 1 minute. 10:1 means 10 minutes and 10 seconds. 100 means 100 minutes.





<p>Volume Screen</p>	 <p>The information displayed: Keypad control mode, set the target volume to 600mL, stop status, clockwise direction</p>	<ul style="list-style-type: none"> On the Volume screen, the displayed unit is uL, mL or L, indicating the three-digit number on the screen represents the volume. The screen also shows the start/stop status, the running direction and the control mode. When the pump is on standby, the volume can be set from 0 to 999L. When the volume is set to 0, the pump will run in continuous transfer mode. When the volume is set to other values, the pump will run in volume transfer mode. When the pump starts running, it will begin calculating the pumped volume based on the flow rate displayed on the Flow Rate Screen and the elapsed running time. And the screen will show the pumped volume. When the preset target volume is reached, the pump will automatically stop. If the volume is set to 0uL, and the pumped volume exceeds the max display value of 999L, the displayed volume will start again from 0uL. The flow rate should be calibrated when running the pump for the first time, after replacing the pump head, or after replacing the tubing. So that the displayed volume will match the actual pumped volume.
<p>Calibration Screen</p>	 <p>The information displayed: Keypad control mode, calibrate the flow rate with the pumped volume of 600mL, stop status, clockwise direction</p>  <p>The information displayed: Keypad control mode, calibrate the flow rate with the actual flow rate of 600mL/m, stop status, clockwise direction</p>	<ul style="list-style-type: none"> CAL indicates the current screen is the Calibration Screen. The Calibration Screen is used to calibrate the flow rate. After calibration, the displayed flow rate on the Flow Rate Screen and the pumped volume on the Volume Screen will match the actual values. The flow rate can be calibrated by using the actual pumped volume or actual flow rate. Press and hold the Unit Switch Key  to switch the unit between the volume unit and the flow rate unit. Refer to Chapter 3.4 for the calibration process details. The flow rate should be calibrated when running the pump for the first time, after replacing the pump head, or after replacing the tubing.

Note:

- When the pump is powered up, the LCD will display one of the run screens: Pump Speed Screen, Time Screen, or Volume Screen, depending on the pump work mode before power off. If the pump was in the continuous work mode (target time and target volume were set to 0), the pump will display the Pump Speed Screen. If the pump was in the timed transfer mode (target time was set to a value other than 0, and the volume was calculated based on the time and flow rate), the pump will display the Time Screen. If the pump was in the volume transfer mode (target volume was set to a value other than 0, and the time was calculated based on the volume and flow rate), the pump will display the Volume Screen.
- When the pump speed and flow rate are 0, the pump can not start.
- When the target volume or target time is set too small, the pump can not start
- When pump is working in the external signal control mode or communication control mode, the LCD can display Pump Speed Screen, Flow Rate Screen, Time Screen and Volume Screen.

3.2.3 Parameter Setting by Keypad

In any control mode and on any run screen, when the pump is on standby, press and hold the Function Key  to enter the Parameter Setting Screen. Refer to the below table for the parameters that can be set through the keypad and the options.

When the pump displays any parameter setting screen, tap the Function Key  or the Enter Key  to switch the setting screen for different parameters. Tap Increase and Decrease Keys  to switch among the parameter options. After the parameter setting, tap the Enter Key  to confirm and save the setting, and show the next parameter setting screen. When all the parameters have been set up, press and hold the Function Key  to return to the previous run screen, then the pump can be controlled to start.

LONGER Instructions for use of peristaltic pump

Item	Parameters	Options
1	Control Mode	INT: for keypad control (start/stop can be controlled by the keypad, a footswitch and an external signal) EXT: for external signal control COM: for communication control
2	Pump status when powered up (only valid for INT mode and continuous transfer mode)	<input checked="" type="checkbox"/> :when powered up, the pump will return to its previous status before power-off <input type="checkbox"/> :when powered up, the pump will stop
3	Keypad lock	OFF: keypad will not lock 0:05-1:00 (5s-1min): keypad will lock when the keypad is not operated within the set time
4	External control speed signal (only valid for the EXT mode)	0-5V, 0-10V, 4-20mA, 0-10kHz
5	Max speed for the external control signal (only valid for the EXT mode)	Setting range for G100-1L: (min speed+1rpm) to 150rpm Setting range for G300-1L: (min speed+1rpm) to 350rpm Setting range for G600-1L: (min speed+1rpm) to 650rpm The default value of min speed is 0rpm. The min speed can be set by communication command.
6	Start/Stop control trigger mode	Pulse trigger (maintained) Level trigger (momentary)
7	Running direction control trigger mode (only valid for the EXT)	Pulse trigger (maintained) Level trigger (momentary)
8	Pump address for the communication control	1-30
9	Baud rate for the communication control	1200bps, 2400bps, 4800bps, 9600bps, 19200bps, 38400bps, 115200bps
10	Parity for the communication control	None EVEN ODD

LONGER Instructions for use of peristaltic pump

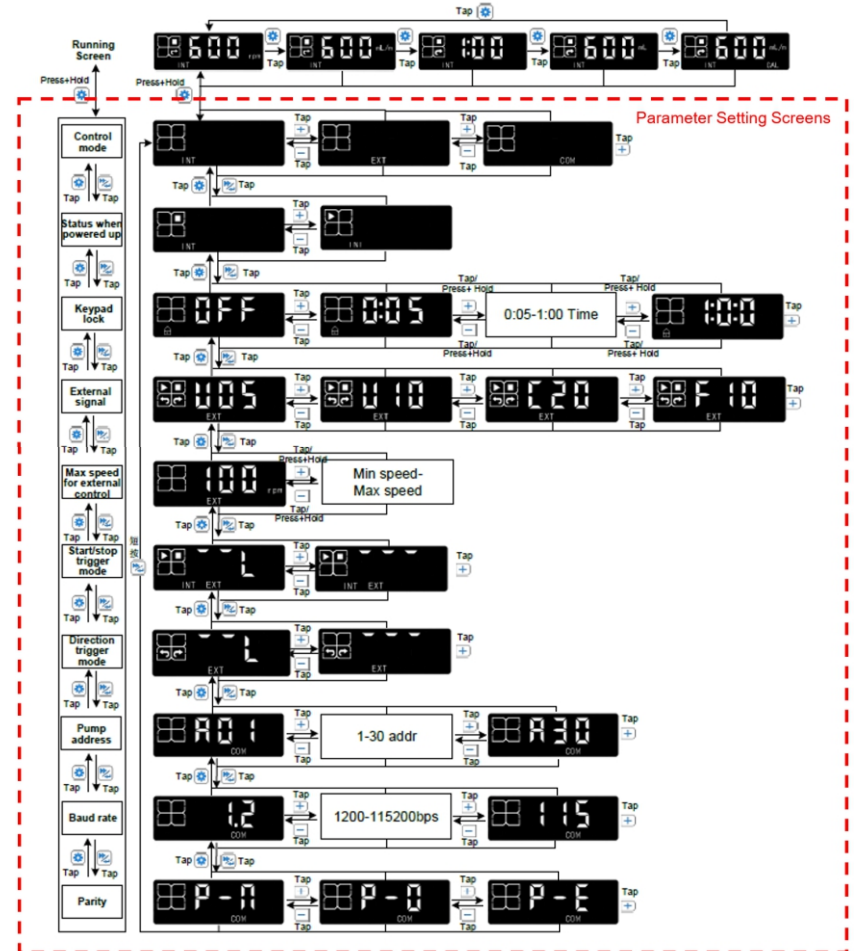

3.2.3.1 Control Mode Setting

There are three control modes: keypad control mode, external signal control mode and communication control mode. In the keypad control mode, the start/stop can be controlled by the keypad, a footswitch and an external signal.

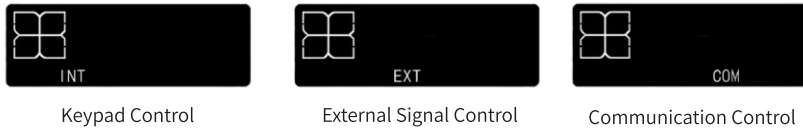

Setting steps:

1. When the pump is on standby and displaying any run screen, press and hold the Function Key to enter the Control Mode setting Screen.
2. Tap Increase and Decrease Keys to switch among the control modes. INT means keypad control, EXT means external signal control, COM means communication control.
3. Tap the Enter Key to confirm and save the control mode setting, and display the next parameter setting screen (Pump Status When Powered Up).
4. If no other parameters need to be set, press and hold the Function Key to return to the previous run screen. The pump only can start running when displaying run screen.

3.2.3.2 Pump Status When Powered Up

When the control mode is the keypad control and work mode is continuous transfer, the pump status when powered up can be set to stop or the status before power-off.



When powered up, pump will stop



When powered up, pump will return to its previous status before power-off

Setting steps:

1. When the pump is on standby and displaying any run screen, press and hold the Function Key to enter the Control Mode setting screen. Then tap Enter Key to enter the Pump Status When Powered Up setting screen.
2. Tap Increase and Decrease Keys to switch between the two statuses. : when powered up, pump will return to its previous status before power-off. :when powered up, pump will stop.
3. Tap the Enter Key to confirm and save the setting, and display the next parameter setting screen (Keypad Lock).
4. If no other parameters need to be set, press and hold the Function Key to return to the previous run screen. The pump only can start running when displaying run screen.

Note: the setting for pump status when powered up is only valid for the keypad control mode and the continuous work mode. When pump is working at timed mode or volume mode, the pump will always stop when powered up.

3.2.3.3 Keypad lock

When the pump displays the run screen, the keypad can lock automatically to prevent misoperation. The time before lock can be set to 5s - 1min.









The keypad will never lock



The keypad will lock when it is not operated within 1min

Setting steps:

1. When the pump is on standby and displaying any run screen, press and hold the Function Key  to enter the Control Mode setting screen. Then tap Enter Key  twice to enter the Keypad Lock setting screen.
2. Tap Increase and Decrease Keys   to set the keypad lock delay time.
3. Tap the Enter Key  to confirm and save the setting, and display the next parameter setting screen (Speed Signal).
4. If no other parameters need to be set, press and hold the Function Key  to return to the previous run screen. The pump only can start running when displaying run screen.

Note:







1. When the keypad is locked, press and hold the Function Key  to unlock the keypad.
2. Keypad lock function is valid for keypad control mode, external signal control mode and communication control mode.

3.2.3.4 External Control Speed Signal

When using an external signal to control the pump, the pump speed signal can be 4-20mA, 0-5V, 0-10V, 0-10kHz. Before controlling the pump, the speed signal should be set up on the pump.



Setting steps:

1. When the pump is on standby and displaying any run screen, press and hold the Function Key  to enter the Control Mode setting screen. Then tap Enter Key  three times to enter the Speed Signal setting screen.
2. Tap Increase and Decrease Keys   to set the speed signal.
3. Tap the Enter Key  to confirm and save the setting, and display the next parameter setting screen (Max Speed for External Control).
4. If no other parameters need to be set, press and hold the Function Key  to return to the previous run screen. The pump only can start running when displaying run screen.

Note: when the pump is in the external signal control mode, and the pump is displaying the run screen, tap Enter Key  to check the speed signal setting.

3.2.3.5 Max Speed for the External Control

In the external signal control mode, the max speed corresponding to the max speed signal can be set.

Setting range for G100-1L: (min speed+1rpm) to 150rpm

Setting range for G300-1L: (min speed+1rpm) to 350rpm







Setting range for G600-1L: (min speed+1rpm) to 650rpm

The default value of min speed is 0rpm. The min speed can be set through communication command.



The max speed is set to 100rpm

Setting steps:

1. When the pump is on standby and displaying any run screen, press and hold the Function Key  to enter the Control Mode setting screen. Then tap Enter Key  to enter the Control Mode setting screen. Then tap Enter Key   to set the max speed corresponding to the max speed signal.
2. Tap the Enter Key  to confirm and save the setting, and display the next parameter setting screen (Start/stop Trigger Mode).
3. If no other parameters need to be set, press and hold the Function Key  to return to the previous run screen. The pump only can start running when displaying run screen.

3.2.3.6 Start/stop Control Trigger Mode

When using an external logic level signal or a switch signal (dry contact signal or footswitch) to start or stop the pump, the trigger mode can be set to pulse trigger (maintained) or level trigger (momentary). Through the keypad, the pulse trigger mode can be set to failing edge trigger, the level trigger mode can be set to high level signal trigger. Through the

communication commands, the pulse trigger mode can be set to failing edge trigger or rising edge trigger, the level trigger can be set to high level signal trigger or low level signal trigger.



Failing Edge Trigger



Rising edge Trigger



High Level Signal Trigger



Low Level Signal Trigger

Failing Edge Trigger: When the control signal is a logic level signal, a change from high (5V to 24V) to low level is considered a failing edge signal. When the control signal is a switch signal (dry contact), a change from open to closed contact is considered a failing edge signal. Upon receiving a failing edge signal, the pump will toggle its status between start and stop.

Rising Edge Trigger: When the control signal is a logic level signal, a change from low to high level (5V to 24V) is considered a rising edge signal. When the control signal is a switch signal (dry contact), a change from closed to open contact is considered a rising edge signal. Upon receiving a rising edge signal, the pump will toggle its status between start and stop.

High Level Signal Trigger: When the control signal is a logic level signal, a voltage of 5V to 24V is considered high level. When the control signal is a switch signal (dry contact), an open contact is considered high level, and a closed contact is considered low level. When the signal changes from low level to high level, and remains high level, the pump will start.

Low Level Signal Trigger: When the control signal is a logic level signal, a voltage of 5V to 24V is considered high level. When the control signal is a switch signal (dry contact), an open contact is considered high level, and a closed contact is considered low level. When the signal changes from high level to low level, and remains low level, the pump will start.

Setting steps:

1. When the pump is on standby and displaying any run screen, press and hold the Function Key to enter the Control Mode setting screen. Then tap Enter Key five times to enter the Start/Stop Trigger Mode setting screen.
2. Tap Increase and Decrease Keys to set the trigger mode.
3. Tap the Enter Key to confirm and save the setting, and display the next parameter setting screen (Running Direction Trigger Mode).
4. If no other parameters need to be set, press and hold the Function Key to return to the previous run screen. The pump only can start running when displaying run screen.

3.2.3.7 Running Direction Control Trigger Mode

When using an external logic level signal or a switch signal (dry contact signal or footswitch) to control the running direction of the pump in the external signal control mode, the trigger mode can be set to pulse trigger (maintained) or level trigger (momentary). Through the keypad, the pulse trigger mode can be set to failing edge trigger, the level trigger mode can be set to high level trigger. Through the communication commands, the pulse trigger mode can be set to failing edge trigger or rising edge trigger, the level trigger mode can be set to high level signal trigger or low level signal trigger.



Failing Edge Trigger



Rising edge Trigger



High Level for CW



Low Level for CW





Failing Edge Trigger: When the control signal is a logic level signal, a change from high (5V to 24V) to low level is considered a failing edge signal. When the control signal is a switch signal (dry contact), a change from open to closed contact is considered a failing edge signal. Upon receiving a failing edge signal, the pump will toggle its running direction between clockwise and counterclockwise.

Rising edge Trigger: When the control signal is a logic level signal, a change from low to high level (5V to 24V) is considered a rising edge signal. When the control signal is a switch signal (dry contact), a change from closed to open contact is considered a rising edge signal. Upon receiving a rising edge signal, the pump will toggle its running direction between clockwise and counterclockwise.

High Level Signal for CW: When the control signal is a logic level signal, a voltage of 5V to 24V is considered high level. When the control signal is a switch signal (dry contact), an open contact is considered high level, and a closed contact is considered low level. When the signal is high level, the pump will run clockwise. When the signal is low level, the pump will run counterclockwise.

Low Level Signal for CW: When the control signal is a logic level signal, a voltage of 5V to 24V is considered high level. When the control signal is a switch signal (dry contact), an open contact is considered high level, and a closed contact is considered low level. When the signal is high level, the pump will run counterclockwise. When the signal is low level, the pump will run clockwise.

Setting steps:

1. When the pump is on standby and displaying any run screen, press and hold the Function Key  to enter the Control Mode setting screen. Then tap Enter Key  six times to enter the Running Direction Trigger Mode setting Screen.
2. Tap Increase and Decrease Keys  to set the trigger mode.
3. Tap the Enter Key  to confirm and save the setting, and display the next parameter setting screen (Pump Address).
4. If no other parameters need to be set, press and hold the Function Key  to return to the previous run screen. The pump only can start running when displaying run screen.

3.2.3.8 Pump Address for the Communication Control

When using communication commands to set the parameters and control the pump, the pump address can be set to 1-30.







Pump Address 01



Pump Address 30

Setting steps:

1. When the pump is on standby and displaying any run screen, press and hold the Function Key  to enter the Control Mode setting screen. Then tap Enter Key  seven times to enter the Pump Address setting screen.
2. Tap Increase and Decrease Keys  to set the pump address.
3. Tap the Enter Key  to confirm and save the setting, and display the next parameter setting screen (Baud Rate).
4. If no other parameters need to be set, press and hold the Function Key  to return to the previous run screen. The pump only can start running when displaying run screen.

3.2.3.9 Baud Rate for the Communication Control

When using communication commands to set the parameters and control the pump, the baud rate can be set to 1200bps (displayed as 1.2), 2400bps (displayed as 2.4), 4800bps (displayed as 4.8), 9600bps (displayed as 9.6), 19200 (19.2), 38400bps (displayed as 384), 115200bps (displayed as 115).







Baud rate is 1200bps



Baud rate is 115200bps

Setting steps:





1. When the pump is on standby and displaying any run screen, press and hold the Function Key  to enter the Control Mode setting screen. Then tap Enter Key  eight times to enter the Baud Rate setting screen.
2. Tap Increase and Decrease Keys  to set the baud rate.
3. Tap the Enter Key  to confirm and save the setting, and display the next parameter setting screen (Parity).
4. If no other parameters need to be set, press and hold the Function Key  to return to the previous run screen. The pump only can start running when displaying run screen.

3.2.3.10 Parity for the Communication Control

When using communication commands to set the parameters and control the pump, the parity can be set to NON, ODD, EVEN.



Setting steps:

1. When the pump is on standby and displaying any run screen, press and hold the Function Key  to enter the Control Mode setting screen. Then tap Enter Key  nine times to enter the Parity setting screen. Or tap Function Key once to enter the Parity setting screen.
2. Tap Increase and Decrease Keys  to set the parity.
3. Tap the Enter Key  to confirm and save the setting, and display the next parameter setting screen (Control Mode).
4. If no other parameters need to be set, press and hold the Function Key  to return to the previous run screen. The pump only can start running when displaying run screen.

3.3 Flow Rate Calibration

Gx00-1L series pump can display flow rate and pumped volume, and operate according to the preset target volume. To ensure the displayed flow rate and volume match the actual values, and the pumped volume meets the set target volume, it is necessary to calibrate the flow rate before the pump starts official operation, or after replacing the pump head or tubing.

The flow rate can be calibrated by using the actual pumped volume or actual flow rate. And the calibration can be performed in keypad control mode or communication control mode. External control mode does not support the calibration function.





3.3.1 Flow Rate Calibration in Keypad Control Mode

3.3.1.1 Calibration with Volume



Calibration Screen with Volume

Calibration steps:

1. When the pump displays any run screen, tap the Function Key  to display the calibration screen.
2. Press and Hold the Unit Switch Key  to change the unit to a volume unit.
3. Start the pump, and the pump will begin timing automatically.
4. Stop the pump at any time. (If the pump was set with target time in Time Screen or target volume in Volume Screen, the pump will stop automatically when the target time is reached or the target volume is reached.)
5. Tap the Increase and Decrease Keys  to change the three-digit value according to the actual pumped volume during the running time.
6. Tap the Enter Key  to calibrate, and the LCD will show "CAL" for 2 seconds.

Note:





1. After calibration, the pump speed will adjust to match the flow rate set before calibration.
2. After calibration, if the pump speed needs to be set higher than the max speed (the max speed of G100-1L is 150rpm, the max speed of G300-1L is 350rpm, the max speed of G600-1L is 650rpm.), the LCD will show “err” for 2 seconds, and the pump speed will adjust to the max speed, and the flow rate will change to the max flow rate at the max speed. This indicates that the set flow rate exceeds the capacity of the loaded tubing.

3.3.1.2 Calibration with Flow Rate



Calibration Screen with Flow Rate





If the pump is working in timed transfer mode or volume transfer mode, calibrate the flow rate as below steps:

1. When the pump displays any run screen, tap the Function Key  to display the calibration screen.
2. Press and Hold the Unit Switch Key  to change the unit to a flow rate unit.
3. Start the pump, and the pump will begin timing automatically.
4. Stop the pump at any time, or wait for the pump to stop automatically when the target time is reached or the target volume is reached.
5. Tap the Increase and Decrease Keys  to change the three-digit value according to the actual flow rate corresponding to the current pump speed.
6. Tap the Enter Key  to calibrate, and the LCD will show “CAL” for about 2 seconds.

Note:

1. After calibration, the pump speed will adjust to match the flow rate set before calibration.
2. After calibration, if the pump speed needs to be set higher than the max speed (the max speed of G100-1L is 150rpm, the max speed of G300-1L is 350rpm, the max speed of G600-1L is 650rpm.), the LCD will show “err” for 2 seconds, and the pump speed will adjust to the max speed, and the flow rate will change to the max flow rate at the max speed. This indicates that the set flow rate exceeds the capacity of the loaded tubing.

If the pump is working in continuous transfer mode, calibrate the flow rate as below steps.

1. When the pump displays any run screen, tap the Function Key  to display the calibration screen.
2. Press and Hold the Unit Switch Key  to change the unit to a flow rate unit.
3. Start the pump or not.
4. Tap the Increase and Decrease Keys  to change the three-digit value according to the actual flow rate corresponding to the current pump speed.
5. Tap the Enter Key  to calibrate, and the LCD will show “CAL” for about 2 seconds.

Note:

1. After calibration, the pump speed will adjust to match the flow rate set before calibration.
2. After calibration, if the pump speed needs to be set higher than the max speed (the max speed of G100-1L is 150rpm, the max speed of G300-1L is 350rpm, the max speed of G600-1L is 650rpm.), the LCD will show “err” for 2 seconds, and the pump speed will adjust to the max speed, and the flow rate will change to the max flow rate at the max speed. This indicates that the set flow rate exceeds the capacity of the loaded tubing.

3.3.2 Flow Rate Calibration in Communication Control Mode

When the pump is working in Communication Control Mode, the flow rate can be calibrated by receiving the actual pumped volume during the running time, or the actual flow rate. Please refer to Appendix 2 for the Modbus RTU protocol for the register addresses of calibration parameter, calibration value, and calibration unit.

Note:

1. After calibration, the pump speed will be changed to the value corresponding to the set flow rate. And the flow rate will remain the same as the one set before calibration.
2. After calibration, if the pump speed needs to be changed to a value higher than the max speed (the max speed of G100-1L is 150rpm, the max speed of G300-1L is 350rpm, the max speed of G600-1L is 650rpm.), the LCD will show “er1” for 2 seconds, and the pump speed will be changed to the max speed, and the flow rate will be changed to the value corresponding to the max speed. This means the set flow rate is out of the loaded tubing capacity.

4. Definition of the External Control Interface

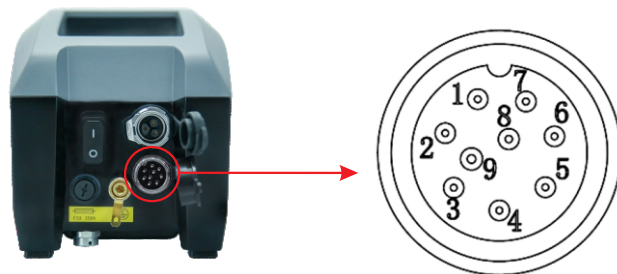

PIN	Functional Definition	Description	Wiring Instruction
1	START/STOP	Start/stop signal input	<p>(1) Using a voltage signal or frequency signal to control the pump speed:</p> <p>(2) Using a current signal to control the pump speed:</p> <p>(3) Using an external signal (e.g. foot pedals) to control the start/stop of the pump in keypad control mode:</p> <p>(4) To control the start/stop, and running direction, Pin 1 and Pin 2 can be connected to the 5 to 24V voltage signal or dry contact switch signal</p>
2	CW/CCW	Running direction signal input, CW: clockwise, CCW: counterclockwise	
3	V/F	Pump speed control signal input: Voltage signal: 0-5V or 0-10V Frequency signal: 0-10kHz	
4	mA	Pump speed control signal input: 4-20mA	
5	GND	Ground	
6	A	RS485+	
7	B	RS485-	
8	GND	Ground	
9	PE	Protecting Earth	

5. Appendix

Appendix 1: Parameter Default Setting

Set all parameters to factory default setting: During the power-up process, press and hold the function key until the LCD displays “---”. Then tap the “+” or “-” button to display “FFF”, and tap the confirmation key to reset all the parameters to their default settings.

Parameter	Factory Default Setting	Remark
Pump speed on the Pump Speed Run Screen	G100-1L: 100rpm G300-1L: 300rpm G600-1L: 600rpm	Pump will display the Pump Speed Run Screen when powered up for the first time.
Flow rate on the Flow Rate Screen	G100-1L: 500 mL/min G300-1L: 1.5L/min G600-1L: 3L/min	
Target time on the Time Screen	0:00	If the target time and target volume are 0, the work mode is continuous transfer mode.
Target volume on the Volume Screen	0.00uL	
Pumped volume on Calibration Screen	0.00uL	The conversion factor between flow rate and pump speed is the factory default setting.
Control mode	INT	INT means keypad control mode
Powered up status	Stop	
Keypad lock	Never lock	
External pump speed control signal	0-5V	
Max speed for external control	G100-1L: 150 rpm G300-1L: 350 rpm G600-1L: 650 rpm	
The relationship between an external signal and pump speed	The default signal range corresponds to pump speed range: 0rpm to the max speed: G100-1L: 150 rpm G300-1L: 350 rpm G600-1L: 650 rpm	The valid signal range and corresponding speed range can be set through communication commands.
Start/stop control trigger mode	Falling edge trigger	
Running direction control trigger mode	Falling edge trigger	
Pump address	01	
Baud rate	115200bps	
Parity	NON	
Stop bit	1	The communication stop bit cannot be set

Refer to Appendix 2 for the factory default setting for other parameters in the Modbus RTU protocol.

Appendix 2: Modbus RTU Protocol

To control the pump with communication commands, set the control mode to COM through the keypad or by setting the register address of 0x0020 to 1. The pump address, baud rate, parity and stop bit should be the same as the pump setting.

The default settings are: pump address 1, baud rate 115200bps, no parity, 1 stop bit.

Note: some external signal control parameters can also be set through communication commands. The control mode should be COM before setting those external control parameters.

Parameter variable	Register address	Data type	Read/write	Be saved after power off?	Factory setting	Description
Start/stop	0x0001	uint_16	R/W	N	0	0: Stop, 1: Start
Run at the full speed	0x0006	uint_16	R/W	N	0	0: Run at the normal speed 1: Run at the full speed
Pump address	0x0010	uint_16	R/W	Y	1	Setting range: 1-30
Baud rate	0x0011	uint_16	R/W	Y	6	0: 1200bps 1: 2400bps 2: 4800bps 3: 9600bps 4: 19200bps 5: 38400 bps 6: 115200bps
Parity	0x0012	uint_16	R/W	Y	0	0: Non, 1: Odd, 2: Even
Enable communication control mode	0x0020	uint_16	R/W	Y	0	1: enable the communication control mode To enable the communication control mode, set this register to 1 while the pump is in keypad control mode or external signal control mode. Note that keypad control mode and external signal control mode can only be set via the keypad, not through communication commands.
Keypad lock	0x0030	uint_16	R/W	Y	0	0: do not lock the keypad, 5 - 60: 5s-60s, the keypad will lock when it is not operated for the set time

LONGER Instructions for use of peristaltic pump

External signal control setting: Start/stop trigger mode	0x0031	uint_16	R/W	Y	2	bit1: bit0 00: Level trigger. Open contact or high level, pump runs. Closed contact or low level, pump stops. 01: Level trigger. Closed contact or low level, pump runs. Open contact or high level, pump stops. 10: Pulse trigger. Falling edge signal switch the status between start and stop 11: Pulse trigger. Rising edge signal switch the status between start and top
External signal control setting: Running direction trigger mode	0x0032	uint_16	R/W	Y	2	bit1: bit0 00: Level trigger. Open contact or high level, pump runs CW. Closed contact or low level, pump runs CCW. 01: Level trigger. Closed contact or low level, pump runs CW. Open contact or high level, pump runs CCW. 10: Pulse trigger. Falling edge signal switch the direction between CW and CCW 11: Pulse trigger. Rising edge signal switch the direction between CW and CCW.
External signal control setting: Pump speed control signal type	0x0033	uint_16	R/W	Y	0	0: 0 - 5V, 1: 0 - 10V, 2: 4 - 20mA, 3: 0 - 10KHz
External signal control setting: Max speed for external signal control	0x0034	uint_16	R/W	Y	G100-1L: 150 rpm G300-1L: 350 rpm G600-1L: 650 rpm	(min speed set in 0x0035 + 1rpm) to max speed Max speed: G100-1L 150rpm, G300-1L 350rpm, G600-1L 650rpm Data unit: 0.01rpm
External signal control setting: Min speed for external signal control	0x0035	uint_16	R/W	Y	0	0rpm to (max speed set in 0x0034 - 1rpm) Data unit: 0.01rpm
External signal control setting: Min input for the 0-5V speed control	0x0036	uint_16	R/W	Y	0	0V to (max input set in 0x0037 -1V) Data unit: 0.01V

LONGER Instructions for use of peristaltic pump

External signal control setting: Max input for the 0-5V speed control	0x0037	uint_16	R/W	Y	5V	(min input set in 0x0036 +1V) to 5V Data unit: 0.01V
External signal control setting: Min input for the 0-10V speed control	0x0038	uint_16	R/W	Y	0	0V to (max input set in 0x0039 -1V) Data unit: 0.01V
External signal control setting: Max input for the 0-10V speed control	0x0039	uint_16	R/W	Y	10V	(min input set in 0x0038 +1V) to 10V Data unit: 0.01V
External signal control setting: Min input for the 4-20mA speed control	0x003A	uint_16	R/W	Y	4mA	4mA to (max input set in 0x003B - 1.6mA) Data unit: 0.01mA
External signal control setting: Max input for the 4-20mA speed control	0x003B	uint_16	R/W	Y	20mA	(min input set in 0x003A +1.6mA) to 20mA Data unit: 0.01mA
External signal control setting: Min input for the 0-10kHz speed control	0x003C	uint_16	R/W	Y	0	0 to (max input set in 0x003D-1KHz) Data unit: 1Hz
External signal control setting: Max input for the 0-10kHz speed control	0x003D	uint_16	R/W	Y	10KHz	(min input set in 0x003C +1kHz) to 10kHz Data unit: 1Hz
Running direction	0x0060	uint_16	R/W	Y	1	0: counterclockwise, 1: clockwise
Target volume in volume transfer mode	0x0063	uint_16	R/W	Y	0	0 to 9999, max 999L
Unit for the target volume	0x0064	uint_16	R/W	Y	101	99: 100nL, 100: 1uL, 101: 10uL, 102: 100uL, 103: 1mL, 104: 10mL, 105: 100mL, 106: 1L

Target time in timed transfer mode	0x0065	uint_16	R/W	Y	0	0 to 9999, max 999 minutes
Unit for the target time	0x0066	uint_16	R/W	Y	100	100: 1s, 101: 0.1min, 102: 1min
Flow rate	0x0067	uint_16	R/W	Y	G100-1L: 500 G300-1L: 150 G600-1L: 300	0 to 9999 G100 flow rate range: 0-750mL/min G300 flow rate range: 0-1.75L/min G600 flow rate range: 0-3.25L/min
Unit for the flow rate	0x0068	uint_16	R/W	Y	G100-1L: 103 G300-1L: 104 G600-1L: 104	99: 100nL/min, 100: 1uL/min, 101: 10uL/min, 102: 100uL/min, 103: 1mL/min, 104: 10mL/min, 105: 100mL/min, 106: 1L/min
Pump speed	0x0069	uint_16	R/W	Y	G100-1L: 100 G300-1L: 300 G600-1L: 600	0 to 9999 G100 speed range: 0-150rpm G300 speed range: 0-350rpm G600 speed range: 0-650 rpm
Unit for the pump speed	0x006A	uint_16	R/W	Y	100	98: 0.01rpm 99: 0.1rpm 100: 1rpm
Calibration variable	0x00BF	uint_16	R/W	N	2	0: calibrate the pump with pumped volume 2: calibrate the pump with actual flow rate corresponding to the current speed
Actual value for calibration	0x00C0	uint_16	R/W	N	G100-1L: 500 G300-1L: 150 G600-1L: 300	0 to 9999
Unit for the actual value	0x00C1	uint_16	R/W	N	G100-1L: 103 G300-1L: 104 G600-1L: 104	Pumped volume: 99: 100nL, 100: 1uL, 101: 10uL, 102: 100uL, 103: 1mL, 104: 10mL, 105: 100mL, 106: 1L Flow rate: 97: 1nL/min, 98: 10nL/min, 99: 100nL/min, 100: 1uL/min, 101: 10uL/min,

						102: 100uL/min, 103: 1mL/min, 104: 10mL/min, 105: 100mL/min, 106: 1L/min
System Status (High Letter)	0x0100	uint_16	R	N	0	Error Code: BIT0: abnormal status of external signal control BIT1: abnormal status of data reading BIT2: abnormal status of data saving BIT3: the target time or volume is too small to run the pump BIT8: the running time exceeds 999minutes according to the target volume and flow rate BIT9: the volume exceeds 999L according to the target time and flow rate BIT10: Calibration out of range

Appendix 3: Longer Pump OEM Communication Protocol

To control the pump with communication commands, set the control mode to COM through the keypad. The pump address, baud rate, parity and stop bit need to be the same as the pump setting.

The default settings are: pump address 1, baud rate 115200bps, no parity, 1 stop bit.

1. Frame format (Character format): 1start + 8data + 1parity + 1stop
 1 start bit
 8 data bits
 1 parity bit (non, odd or even)
 1 stop bit
2. Message format: flag+addr+len+pdu+fcs.
 flag: E9H, the message head. When sending the message, the data E8H after message head will be replaced with E8H 00H, and E9H after message head will be replaced with E8H 01H. When receiving the message, the data E8H 00H after message head will be reverted to E8H, and E8H 01H after message head will be reverted to E9H.
 (Note: if E8 00 replaced E8 or E8 01 replaced E9, E8 00 or E8 01 will be regarded as one byte, no influence on the length of pdu.)

addr: one byte, pump address, 1-30. 31 is broadcast address.

len: one byte, length of pdu.

fcs: one byte, XOR of addr, len , pdu.

3. pdu format: application layer code format

3.1 Set the pump running parameters

Send to the pump:

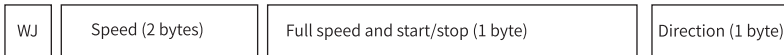

Pump responds:



- WJ: 2 bytes, using ASCII code, to indicate that this command is used to set pump running parameters. ASCII code of W is 57H, ASCII code of J is 4AH.
- Speed: 2 bytes. hexadecimal number, most significant byte first. The data unit is 0.01rpm. Example: 2710H means 100rpm.
- Full speed and start/stop:
Bit0: 1 means pump runs, 0 means pump stops.
Bit1: 1 means full speed, 0 means normal speed.
- Direction:
Bit0: 1 means CW, 0 means CCW.

Note: When setting the running parameter, the addr in message can be pump address (1-30) or broadcast address 31. All pumps will operate according to the same command without response when using broadcast address.

3.2 Read the pump running status

Send to the pump:



Pump responds:

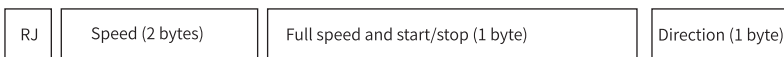

- RJ: 2 bytes, using ASCII code, to indicate that this call is used to read pump running status. ASCII code of R is 52H, ASCII code of J is 4AH.
- Refer to para. 3.1 for instructions of speed, full speed, start/stop, direction

Note: When reading the running state, the addr in the message only can be pump address (1-30).

3.3 Set the flow rate parameters

Send to the pump:



Pump responds:



- WL: 2 bytes, using ASCII code, to indicate that this command is used to set the flow rate parameters. ASCII code of W is 57H, ASCII code of L is 4CH.
- Flow rate: 4 bytes. hexadecimal number, most significant byte first. The data unit is 1nL/min. 1L=103 mL=106 μL=109 nL Example: 5F5 E100H means 100mL/min.
- Refer to para. 3.1 for instructions of full speed, start/stop, direction

Note: When setting the flow rate parameters, the addr in message can be pump address (1-30) or broadcast address 31. All pumps will operate according to the same command without response when using broadcast address.

3.4 Read the flow rate parameters

Send to the pump:



Pump responds:

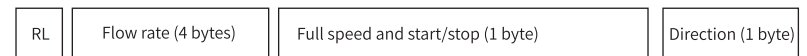

- RL: 2 bytes, using ASCII code, to indicate that this command is used to read flow rate parameters. ASCII code of R is 52H, ASCII code of L is 4CH.
- Flow rate: 4 bytes. hexadecimal number, most significant byte first. The data unit is 1nL/min. 1L=103 mL=106 μL=109 nL Example: 5F5 E100H means 100mL/min.
- Refer to para. 3.1 for instructions of full speed, start/stop, direction

Note: When reading the running state, the addr in the message only can be pump address (1-30).

3.5 Set the target time for timed transfer mode

Send to the pump:



Pump responds:



- WM: 2 bytes, using ASCII code, to indicate that this command is used to set the target time. ASCII code of W is 57H, ASCII code of M is 4DH.
- Unit of the time: 100 means 1s, 101 means 10s, 102 means 1min.
- Target time: 2 bytes, hexadecimal number, most significant byte first. When the unit of the time is 1s, the target time can be set to 0-600, means 0-600s
When the unit of the time is 10s, the target time can be set to 0-600, means 0-6000s
When the unit of the time is 1min, the target time can be set to 0-999, means 0-999mins
- Refer to para. 3.1 for instructions of full speed, start/stop, direction

Note: When setting the target time parameter, the addr in message can be pump address (1-30) or broadcast address 31. All pumps will operate according to the same command without response when using broadcast address.

3.6 Read the target time parameters

Send to the pump:



Pump responds:



- RM: 2 bytes, using ASCII code, to indicate that this command is used to read the target time parameters. ASCII code of R is 52H, ASCII code of M is 4DH.
- Unit of the time: 100 means 1s, 101 means 10s, 102 means 1min.
- Target time: 2 bytes, hexadecimal number, most significant byte first. When the unit of the time is 1s, the target time can be set to 0-600, means 0-600s
When the unit of the time is 10s, the target time can be set to 0-600, means 0-6000s
When the unit of the time is 1min, the target time can be set to 0-999, means 0-999mins
- Refer to para. 3.1 for instructions of full speed, start/stop, direction

Note: When reading the target time, the addr in the message only can be pump address (1-30).

3.7 Set the target volume for volume transfer mode

Send to the pump:



Pump responds:



- WV: 2 bytes, using ASCII code, to indicate that this command is used to set the target volume. ASCII code of W is 57H, ASCII code of V is 56H.
- Target volume: 2 bytes, hexadecimal number, most significant byte first. Setting range: 0-999
- Unit of the volume: 1byte, setting range 98-106
98 - 0.01uL, 99 - 0.1uL, 100 - 1uL, 101 - 0.01mL, 102 - 0.1mL, 103 - 1mL, 104 - 0.01L, 105 - 0.1L, 106 - 1L
- Refer to para. 3.1 for instructions of full speed, start/stop, direction

Note: When setting the target volume parameter, the addr in message can be pump address (1-30) or broadcast address 31. All pumps will operate according to the same command without response when using broadcast address.

3.8 Read the target volume parameter

Send to the pump:

RV

Pump responds:

RV	Target volume (2 bytes)	The unit of the volume (1 byte)	Full speed and start/stop (1 byte)	Direction (1 byte)
----	-------------------------	---------------------------------	------------------------------------	--------------------

- RV: 2 bytes, using ASCII code, to indicate that this command is used to read the target volume. ASCII code of R is 52H, ASCII code of V is 56H.
- Target volume: 2 bytes, hexadecimal number, most significant byte first. Setting range: 0-999
- Unit of the volume: 1byte, setting range 98-106
98 - 0.01uL, 99 - 0.1uL, 100 - 1uL, 101 - 0.01mL, 102 - 0.1mL, 103 - 1mL, 104 - 0.01L, 105 - 0.1L, 106 - 1L
- Refer to para. 3.1 for instructions of full speed, start/stop, direction

Note: When reading the target volume, the addr in the message only can be pump address (1-30).

3.9 Set communication parameters:

Send to the pump:

WID (3 bytes)	Address (1 byte)	Baud rate (2 bytes)	Parity (1 byte)	Stop bit (1 byte)
---------------	------------------	---------------------	-----------------	-------------------

Pump responds:

WID

- WID: 3 bytes, using ASCII code, to indicate that this command is used to set communication parameters. ASCII code of W is 57H, ASCII code of I is 49H, ASCII code of D is 44H.
- Pump address: 1 bytes, hexadecimal number, setting range: 0-30
- Baud rate: 2 bytes, hexadecimal number, most significant byte first. Setting range:1-7
1 – 1200bps, 2 – 2400bps, 3 – 4800bps, 4 – 9600bps, 5 – 19200bps, 6 – 38400bps, 7 – 115200bps
- Parity: 1 byte, 1-Non, 2-Odd, 3-Even
- Stop bit: 1 byte, only can be set to 1.

Note: When setting the communication parameter, the addr in the message can be pump address (1-30) or broadcast address 31. All pumps will operate according to the same command without response when using broadcast address.

3.10 Calibrate the pump with actual flow rate

Send to the pump:

CL	The actual flow rate (4 bytes)
----	--------------------------------

Pump responds:

CL

- CL: 2 bytes, using ASCII code, to indicate that this command is used to calibrate the pump with actual flow rate corresponding to the current speed. ASCII code of C is 43H, ASCII code of L is 4CH.
- Actual flow rate: 4 bytes. hexadecimal number, most significant byte first. The data unit is 1nL/min. 1L=103 mL=106 μL=109 nL Example: 5F5 E100H means 100mL/min.

3.11 Calibrate the pump with pumped volume:

Send to the pump:



Pump responds:



- CV: 2 bytes, using ASCII code, to indicate that this command is used to calibrate the pump with actual pumped volume. ASCII code of C is 43H, ASCII code of V is 56H.
- Actual pumped volume: 2 bytes. hexadecimal number, most significant byte first. Setting range: 0-999.
- Unit for the volume: 1 byte, setting range: 98-106
98 - 0.01uL, 99 - 0.1uL, 100 - 1uL, 101 - 0.01mL, 102 - 0.1mL, 103 - 1mL, 104 - 0.01L, 105 - 0.1L, 106 - 1L

4. Examples:

- (1) To set G100-1L (addr: 01) to run clockwise, the speed is 100rpm. The command string is as follows
E9 01 06 57 4A 27 10 01 01 2E
- (2) To set G100-1L (addr: 01) to run clockwise, and the flow rate is 100mL/min. The command string is as follows
E9 01 08 57 4C 05 F5 E1 00 01 01 03

Appendix 4: Alarm Display

Error Codes	Description	Remark
E01	The communication with the external control board is abnormal	Contact after-sales service
Err	Calibration out of range	Check the calibration value input: 1. If the pump speed after calibration will exceed the max speed, the displayed speed will adjust to the max speed, and the flow rate will change to the max flow rate corresponding to the max speed. 2. If the flow rate after calibration will exceed the pump capacity, the calibration will not be performed.
CAL	The calibration was performed successfully	