

LONGER

## dPOFLEX BPH01 Pump Head Operating Manual

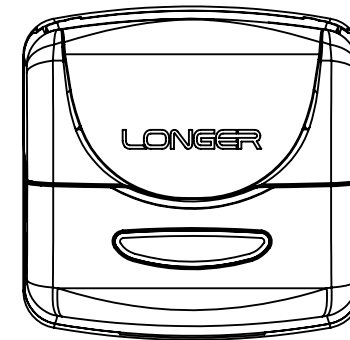

LONGER

**Baoding Longer Precision Pump Co., Ltd.**

Add: 3rd/4th Floor, Building 6B, University Science Park  
Baoding National, High - Tech Industrial Development Zone  
Baoding, Hebei, China 071051  
Tel: 86 - 312 - 3110087 3138553  
Fax: 86 - 312 - 3168553  
E - mail: [longer@longerpump.com](mailto:longer@longerpump.com)  
[Http://www.longerpump.com](http://www.longerpump.com)

2024.6

dPOFLEX BPH01 Pump Head

Baoding Longer Precision Pump Co.,Ltd.

A **Halma** company

# Contents

**1. General Information** ..... 1

1.1 Precautions ..... 1

1.2 Repair Notes ..... 1

1.3 Contacts Information ..... 2

**2. Product Introduction** ..... 2

2.1 Main Features ..... 2

2.2 Unpacking ..... 2

2.3 Pump Head Structure and Dimensions ..... 3

2.4 Specifications ..... 4

2.5 Flow Rate ..... 4

2.6 Pressure ..... 5

**3. Installation** ..... 5

3.1 Pump Head Mounting ..... 5

    3.1.1 Pump Head Mounting Dimension ..... 5

    3.1.2 Panel Mounting ..... 6

    3.1.3 Mounting on Standard Pump Drive of Longer Pump ..... 6



3.2 Tubing Loading ..... 7

    3.2.1 Set the Tubing Clamp Position ..... 8

    3.2.2 Tubing Loading ..... 9

## 1. General Information

### 1.1 Precautions

	<p><b>WARNING</b> Indicates potential hazardous situations that may result in personal injury</p>
	<p><b>WARNING</b> Do not touch moving parts.</p>

- Do not open the pump head and contact the rotor while the pump head/pump drive is running, to prevent mechanical injuries.
- Pay attention to the gaps when opening or closing the flip cover, to prevent mechanical injuries.
- Do not disassemble or assemble the pump head without permission, as improper operation may cause pump head damage or failure.
- Ensure there is no pressure in the tubing before opening the flip cover.
- Make sure fluid in the tubing has been drained out, no pressure in the tubing and disconnect pump from the mains power, while removing or replacing the tubing.
- In the event of tubing leaks or bursts, fluid may spray from both the tubing and pump head. Take necessary precautions to ensure operator safety, including wearing protective clothing and goggles. Regularly inspect the tubing and replace it when necessary to safeguard both operators and equipment.

### 1.2 Repair Notes

Please contact Longer Pump or its distributor, and provide the product serial number before returning the product. Products which has been contaminated with, or exposed to, toxic chemicals or any other substance hazardous to health must be decontaminated before returning to Longer Pump or its distributor. Ship the product in its original packaging or better, to against possible damage or loss during the transport.

**1.3 Contacts Information**

Baoding Longer Precision Pump Co., Ltd  
3rd Floor, Building 6B, University Science Park Baoding National, High -  
Tech Industrial Development Zone, Baoding, Hebei, China 071051  
Email: [longer@longerpump.com](mailto:longer@longerpump.com)  
Tel: [86-312-3110087](tel:86-312-3110087)  
Fax: [86-312-3168553](tel:86-312-3168553)  
[www.longerpump.com](http://www.longerpump.com)

**2. Product Introduction**

**2.1 Main Features**

The dPOFLEX BPH01 is a peristaltic pump head designed and manufactured by Longer Pump. The pump head is compatible with silicone tubing and Pharmed tubing in sizes 13#, 14#, 19#, 16# and 25#, and the max flow rate is 530mL/min. The compact outline dimension makes it suitable for OEM instruments and equipment.

- Small size, compact structure
- Flip-type for easier tubing loading
- Spring-loaded operation for longer tubing life and good pressure control
- Four-roller design for low pulsation
- Accept various tubing sizes (with 1.6mm wall thickness) for a wide flow rate range
- Easier system configuration with AC, DC, stepper, BLDC motors

**2.2 Unpacking**

- 1) Take out the pump and accessories from the shipping carton.
- 2) Check the packing list and confirm that the attachments are intact and complete.
- 3) In case of any questions, please contact Longer Pump or local distributor.

**2.3 Pump Head Structure and Dimensions**

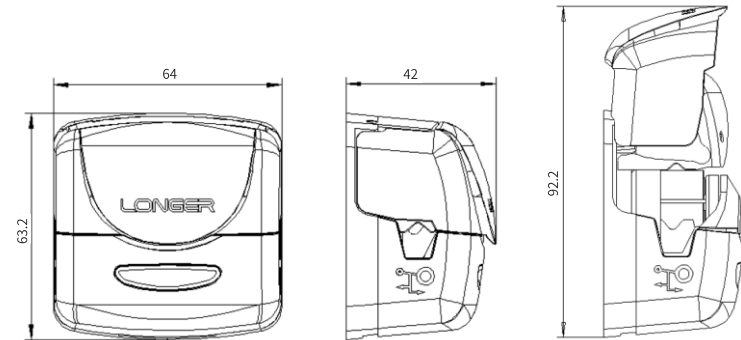
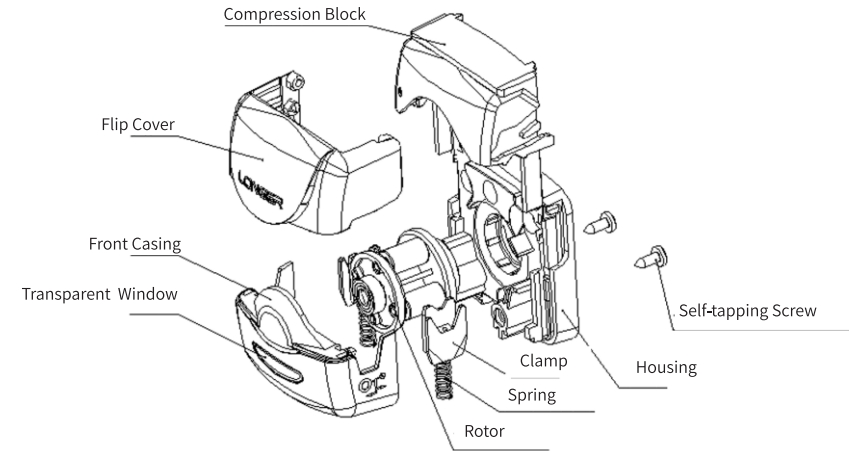

Unit: mm

**2.4 Specifications**

Product model	dPOFLEX BPH01
Outline Dimension	64mm*64mm*42mm
Weight	100g
Speed Range	Continuous flow: speed ≤ 400rpm, intermittent flow 400rpm < speed ≤ 600 rpm
Material	Housing: IXEF Rollers: Nylon + molybdenum disulfide Rotor bracket: Nylon
System Pressure	Pump head compression block can be set for standard pressure and high pressure operation
Tubing Clamps	The spring-loaded tubing clamps feature dual positions, accommodating various tubing inner diameters.
Flow Rate	Continuous flow: reference flow rate ≤ 353mL/min, Intermittent flow: reference flow rate ≤ 530mL/min

**2.5 Flow Rate**

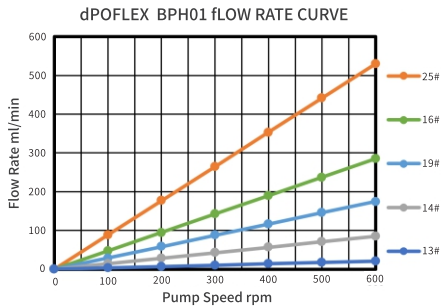

Tubing	Flow Rate Reference (mL/min)	
	@400rpm Continuous	@600rpm Intermittent
13#	14	21
14#	57	85
19#	117	175
16#	190	285
25#	353	530

**Note :** The flow rate is provided for reference only and was tested under the following conditions: water at room temperature, no suction lift, 0 gauge back pressure, compression block set to standard pressure, and clockwise operation. When selecting tubing size, consider factors such as tubing material elasticity, fluid viscosity, and system pressure.

**2.6 Pressure**

To meet the requirements of different pressure conditions, the pump head compression block can be set for standard pressure and high pressure operation.

**The factory default setting is standard pressure. If a high-pressure setting is required, please inform Longer Pump or your local distributor when placing your order.**

Compression Block Setting	Max System Pressure (MPa)				
	13#	14#	19#	16#	25#
Standard Pressure	0.20	0.20	0.16	0.12	0.08
High Pressure	Not recommended	Not recommended	0.20	0.20	0.15

Note: The above data were tested under the conditions: water, PVC tubing, 100rpm, running clockwise. Pressure may vary under different environments, such as different pump speeds, and with different running directions.

**3. Installation**

**3.1 Pump Head Mounting**

**3.1.1 Pump Head Mounting Dimensions**

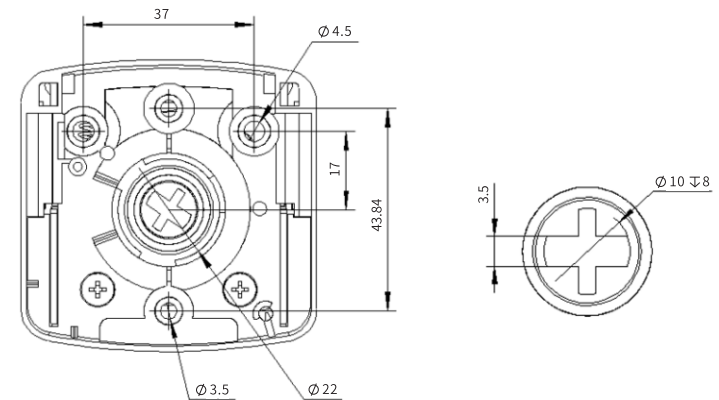

Unit: mm

**3.1.2 Panel Mounting**

OD of the adapter: minΦ6mm, max Φ10mm

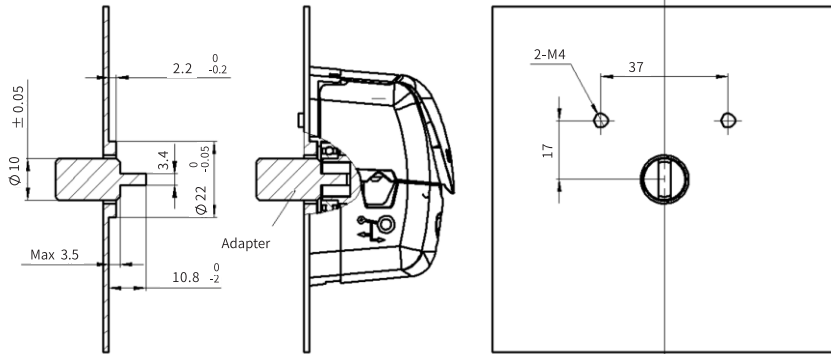

**3.1.3 Mounting on Standard Pump Drive of Longer Pump**

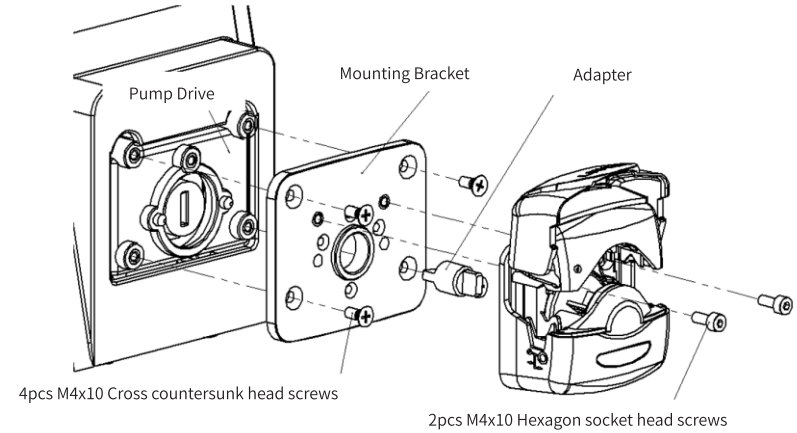
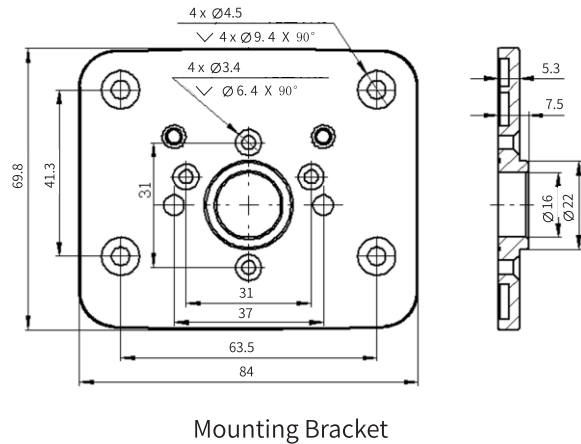

- a) Mount the mounting plate on the pump drive by tightening four mounting screws (M4x10 cross countersunk head screw).
- b) Insert one tang of the adapter into the slot of the motor shaft.
- c) Open the flip cover of the pump head, and insert another tang of the adapter into the slot of the pump head shaft.
- d) Align the two mounting holes on the pump head housing with the mounting holes on the mounting bracket.
- e) Insert the two mounting screws (M4x10 hexagon socket head screws) into the mounting holes and tighten the screws.

**3.2 Tubing Loading**

The spring-loaded tubing clamps can be set at two positions to accommodate various tubing inner diameters.

Tubing Size	13#	14#	19#	16#	25#
ID (mm)	0.8	1.6	2.4	3.2	4.8
Inner Position	✓	✓	✓	✓	×
Outer Position	×	×	✓	✓	✓

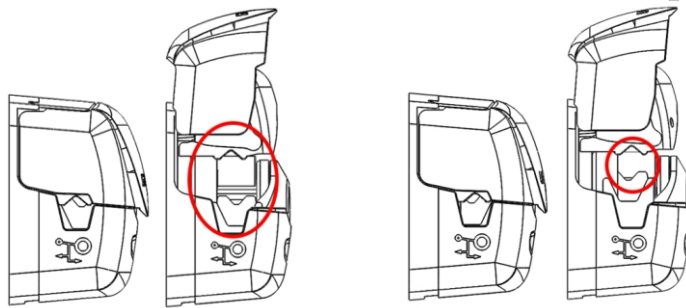

Outer position for large tubing

Inner position for small tubing

- For tubing with an ID of 0.8mm and 1.6mm, the inner position is recommended. The outer position may not hold the tubing securely, potentially causing tubing buildup inside the pump head, which can lead to premature tubing failure.
- For tubing with an ID of 4.8mm, the outer position is recommended. The inner position will decrease the flow rate and tubing life.
- For tubing with an ID of 2.4mm and 3.2mm, both positions can be used based on the application. The inner position will clamp the tubing more securely, but may slightly reduce the flow rate. The outer position poses a risk of tubing dislocation.

**3.2.1 Set the Tubing Clamp Position**

Please disconnect the pump from the mains power before setting the tubing clamp position.

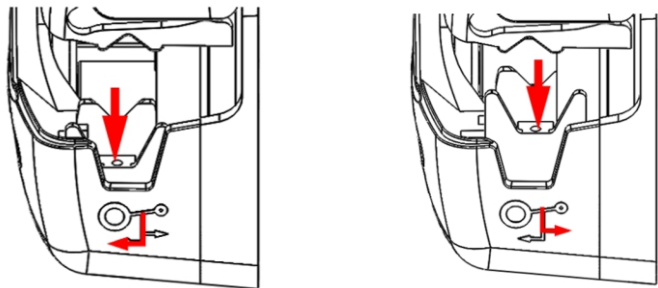

(From the inner position to the outer position)

(From the outer position to the inner position)

1. From the inner position to the outer position (from small tubing to large tubing)

Fully open the flip cover. Place a pointed tool into the groove of the tubing clamp. Press the clamp down, then push it forward towards the front casing of the pump head. Release the pressure, the clamp will rise to the outer position for the large tubing.

2. From the outer position to the inner position (from large tubing to small tubing)

Fully open the flip cover. Place a pointed tool into the groove of the tubing clamp. Press the clamp down, then push it backward towards the back housing of the pump head. Release the pressure, the clamp will rise to the inner position for the small tubing.

**Note:**

- (1) Set the tubing clamp position according to the tubing size.
- (2) The two tubing clamps should be set to the same position.
- (3) If the tubing clamp does not rise to the right position, or the tubing clamp is not vertical relative to the body of the pump head, repeat the procedure.

**3.2.2 Tubing Loading**

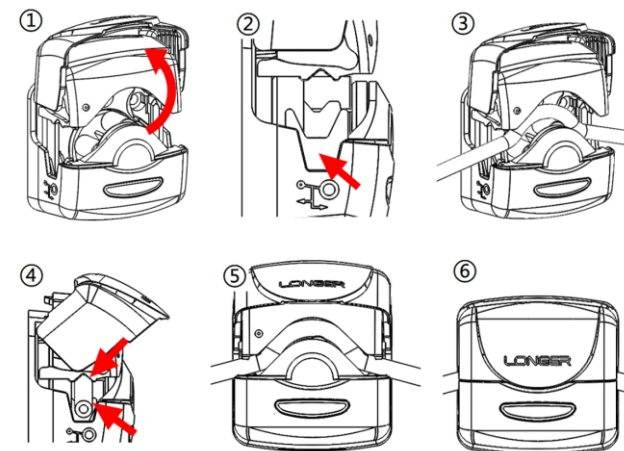

## LONGER dPOFLEX BPH01 Pump Head

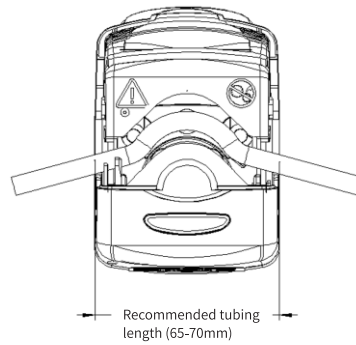

- Fully open the flip cover. (Figure (1))
- Check if the tubing clamp position on both sides of the pump head matches the tubing size to be loaded. If not, set the tubing clamp position accordingly. (Figure (2))
- Place the tubing between the rotor and the compression block. Adjust the tubing's position to avoid twisting or buildup. (Figure (3) and (4))
- Close the flip cover until it is fully secured. Ensure the tubing remains properly aligned inside of the pump head and correctly seated in the clamps throughout this process. (Figure (4)(5)(6))