

# SP4-D1 Industrial Syringe Pump Operating Manual

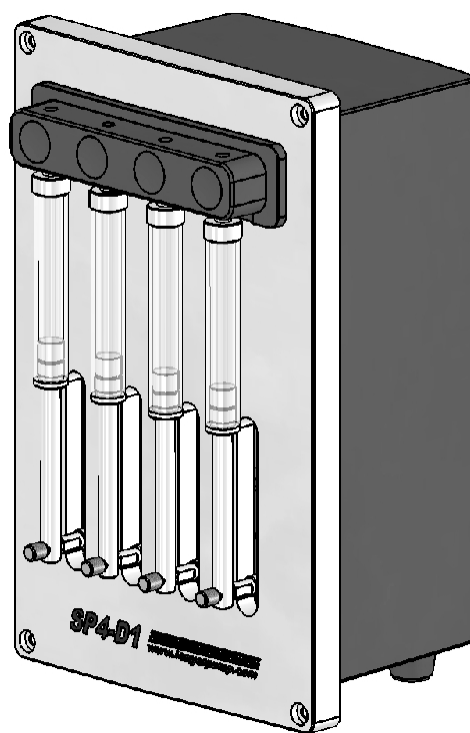

# Contents

1 Product Introduction .....	5
1.1 SP4-D1 Main Features .....	5
1.2 Unpacking .....	5
1.2.1 ESD considerations .....	6
1.3 SP4-D1 Function .....	6
1.3.1 Syringe and Syringe Drive .....	6
1.3.2 Valve Connector .....	7
1.3.3 External Interface of the Control Board .....	8
1.3.4 Communication Interface .....	8
1.3.5 Multi-Pump Configuration .....	8
1.4 Tips for Setting Up the SP4-D1 .....	9
1.5 Power Supply .....	9
1.5.1 Power Supply for a Single Pump .....	9
1.5.2 Power Supply for Multi-Pump .....	10
2 Hardware Setting.....	11
2.1 Power Supply .....	11
2.2 Communication Interface.....	11
2.3 Control Board Setting .....	14
2.3.1 DIP Dial Switch Setting.....	14
2.3.2 Address Switch Setting .....	15
2.3.3 Input/Output.....	16
2.3.4 Solenoid Valve Control Interface.....	17
2.4 SP4-D1 Valve Connector.....	17
2.5 Installing Component.....	17
2.5.1 Install the Syringe .....	18
2.6 Pump Mounting .....	19
3 Software Communication.....	19
3.1 Address Setting .....	20
3.2 Communication Protocol.....	20
3.2.1 OEM Communication Protocol.....	21
3.2.2 DT (Data Terminal) Protocol.....	22
3.2.3 Using DT Protocol with Microsoft Windows .....	23
3.3 Command Set .....	25
3.3.1 Command Execution Guidelines .....	25
3.3.2 Control Commands.....	26
3.3.3 Initialization Commands.....	29
3.3.4 Plunger Movement Command .....	30
3.3.5 Valve Command .....	30
3.3.6 Set Command .....	32
3.3.7 Report Commands .....	32
3.3.8 Error Codes and Pump Status .....	33
4 Setting Up the SP4-D1 for Your Application.....	36

4.1 Glossary .....	36
4.2 Optimizing SP4-D1 Performance .....	38
4.3 Helpful Hints .....	41
5 Maintenance .....	41
5.1 Daily Maintenance .....	41
5.2 Weekly Maintenance .....	41
5.2.1 Weak Detergent Cleaning .....	42
5.2.2 Weak Acid-Base-Sequence Cleaning .....	42
5.2.3 10% Bleach Cleaning .....	42
5.3 Periodic Maintenance .....	43
5.3.1 Quality Control Assurance .....	43
5.3.2 Replacing Dispense or Reagent Tubing .....	44
5.3.3 Replacing a Syringe .....	45
6 Technical Service .....	46
Appendix A Plunger Information .....	47
Appendix B ASCII Chart .....	48
Appendix C Chemical Resistance Chart .....	50
Appendix D Technical Specification .....	53
Appendix E SP4-D1 Command Quick Reference .....	54
Control Commands (for operating and execution) .....	54
Initialization Commands .....	55
Plunger Movement Commands .....	55
Valve Commands .....	56
Set Commands .....	56
Report Commands .....	57
Error Codes .....	57
Error Code and Pump Status .....	58
DB-15 Pin Definition .....	58
DIP Dial Switch Setting .....	59



Please read this operating manual carefully before using the product.

The contents of this publication are presented for informational purposes only, and while every effort has been made to ensure their accuracy. Longer accepts no liability for errors or omissions.

Longer reserves the right to modify or improve the designs or specifications of such products at any time without notice. Please contact with Longer or certified distributor for up-to-date manuals.

## No warranty is expressed or implied for:

- Any damage or failure caused by improper installation, storage, maintenance or usage, not in compliance with operating manual.
- Any damage or failure caused by attempts by personnel other than authorized Longer representatives to install, repair, modify or remove the product.
- Damage or failure caused by not returning pumps in original or adequate packaging
- Syringes
- Syringe seals
- Tubing and tubing connections
- Valves

## Important Safety Instructions:

- If the syringe is damaged, it may result in liquid spills. Please take caution to prevent injury to the operator.
- If liquid spills on the mechanism unit, the operator should turn off the power supply immediately. After wiping the pump dry, re-power the pump.
- For maintenance, please contact Longer company or an authorized Longer distributor. Do not open the device case yourself.
- Shut off the power supply and replace the power cord if it is worn or damaged.
- Unplug the power plug if there is any damage or wear to the power cord or power plug.
- Turn off the power supply before installing any peripheral equipment.

# 1 Product Introduction

SP4-D1 is a compact industry syringe pump, and is mainly used for high precision fluid transfer in OEM application. 4 syringes with capacity of 5ml or less can be installed on one pump to realize 4 channels synchronously running. The pump is equipped with valve connector for easy external valve connection. And the pump outputs 4 external control signals to control external solenoid valves to cooperate with plunger movement for aspirating and dispensing operation.

This chapter includes below topics:

- SP4-D1 main features
- Unpacking SP4-D1
- SP4-D1 function
- Tips for setting up the SP4-D1
- Power supply requirement

**Note: SP4-D1 is not a medical device, and it is not subject to FDA regulatory approval.**

## 1.1 SP4-D1 Main Features

- Syringe sized: 50uL, 100uL, 250uL,500uL, 1mL, 2.5mL, 5mL
- Travel control accuracy:  $\leq\pm 1\%$  (Full stroke)
- Full stroke: 60mm (1000steps)
- Control resolution: 0.06mm (1step)
- Applicable valve: energize or de-energize the external solenoid valves by outputting 24VDC voltage (current 200mA) or not.
- Wetted material: Borosilicate glass, PTFE, PPS, PP
- Communication interface: RS-232/RS-485
- Time for rated stroke: 2.5s-2000s
- Linear speed: 0.03mm/s-24mm/s
- Operates using a single 24VDC power supply

## 1.2 Unpacking

To unpack the controller, follow below steps:

- 1) Take out the pump and accessories from the shipping carton.
- 2) Check the packing list to make sure all components are present.

## 1.2.1 ESD considerations

SP4-D1 is an electronic device that is sensitive to electrostatic discharge. Static discharge from clothing or other materials can damage the pump. In order to prevent the electrostatic damage, please follow below practices:

- Using antistatic gloves or wrist straps
- Using ESD bench or mat
- Using antistatic floor

Prepare an ESD-free work area before the chassis is grounded.

## 1.3 SP4-D1 Function

SP4-D1 uses step motor to drive plungers of syringes to aspirate and dispense measured quantities of liquid. The syringes are replaceable. The function and illustration of major components are provided in the following sections.

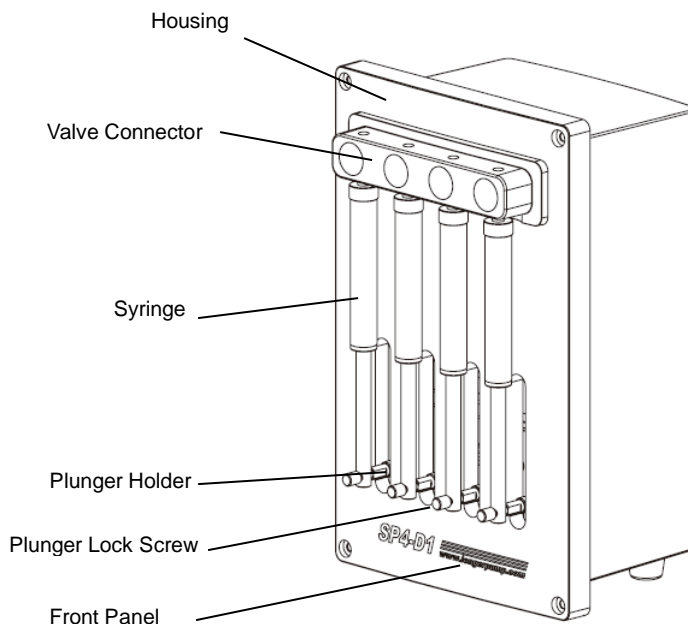

**Figure 1-1 SP4-D1 Syringe Pump**

### 1.3.1 Syringe and Syringe Drive

The syringe plunger is held to the plunger holder. The plunger moved within the syringe barrel driven by the step motor. The syringe barrel attaches to the valve connector by a 1/4-28 fitting.

The full stroke of the syringe drive is 60mm, divided into 1000 steps, resolution is 1 step.

Refer to Figure 1-2 for the components of the syringe:

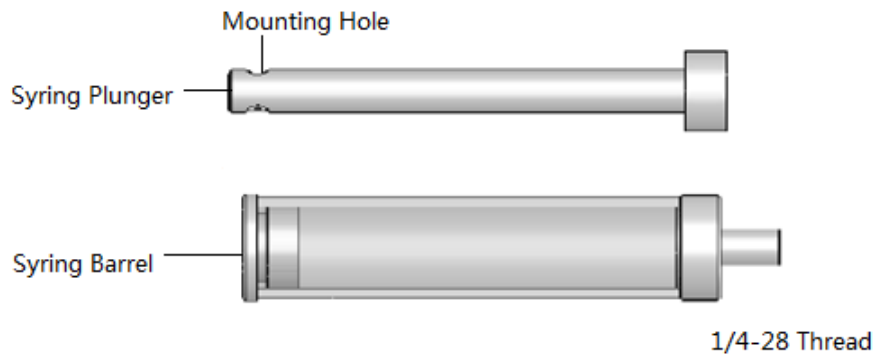

**Figure 1-2 Syringe Components**

Refer to Figure 1-3 for holding the syringe plunger:

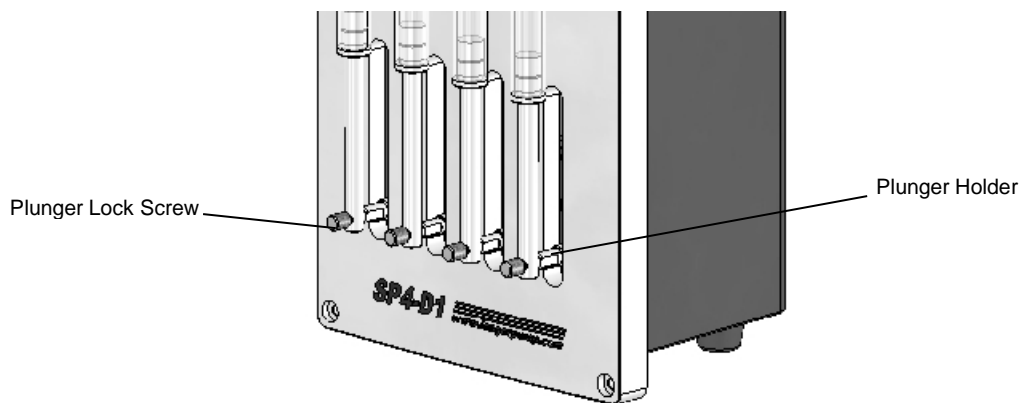
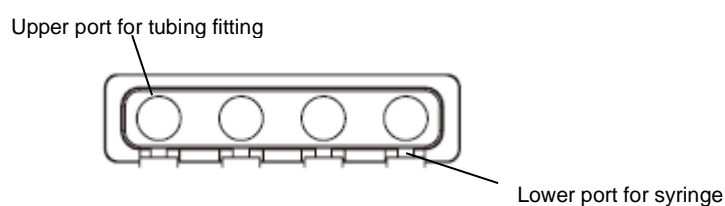

**Figure 1-3 Holding the Plunger**

Available syringe sizes: 50uL,100uL,250uL,500uL,1.0mL,2.5mL,5.0mL

## 1.3.2 Valve Connector

The valve connectors has 4 fluid paths. Each path has 2 ports with 1/4-28 UNF thread. Upper port is for tubing fitting, which can be connected to external valves. The lower port is for syringe.



**Figure 1-4 Valve Connector**

### 1.3.3 External Interface of the Control Board

The control board, used to control the syringe plunger and external solenoid valve, includes microprocessor and circuitry. The external interfaces of control board include DIP dial switch for operating model selection, Address Switch and DB15 external control port. The communication interface can be set through DIP dial switch. Please refer to Chapter 3 “Software Communication” for more details.

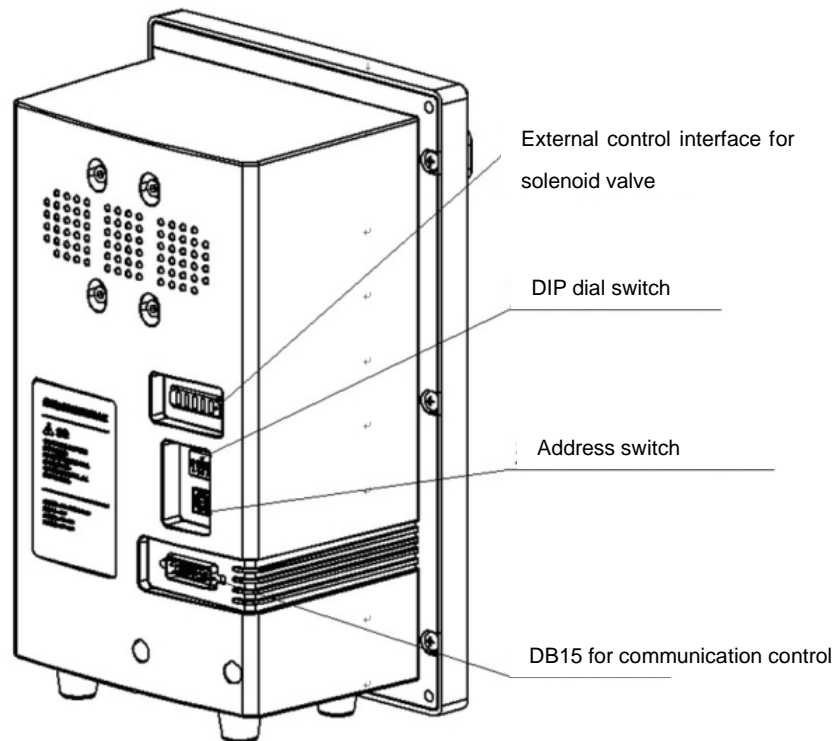

**Figure 1-5 The External Interface of the Control Board**

Please refer to Chapter 2 “Hardware Setting” for more information about input/output, dial switch and address switch.

### 1.3.4 Communication Interface

The SP4-D1 can communicate either individually or in a multi-pump configuration using an RS-232 or RS-485 interface. The baud rate options are 9600bps or 38400bps.

Please refer to Chapter 2, “Hardware Setting” for more information about the communication interface.

### 1.3.5 Multi-Pump Configuration

Up to 15 SP4-D1 pumps can be connected together in a multi-pump configuration. Within a multi-pump configuration, the RS-485 communications bus is required, although the



first pump in the daisy chain maybe connected to PC through either RS-232 or RS-485 interface. The PC can communicate with each pump through the pump's unique address. The pump address can be set through the Address Switch on the back panel of the pump. Please refer to the Chapter 2, "Hardware Setting" for more information about the pump address setting.

## 1.4 Tips for Setting Up the SP4-D1

Please refer to Chapter 2 "Hardware Setting" and Chapter 3 "Software Communication" for complete information for setting up the SP4-D1.

To ensure proper operation, follow below tips:

- Always set up and mount the pump in upright position to avoid damaging the syringe barrel and plunger.
- Please refer to the "Chemical Resistance Chart" before pumping any organic solvents.
- Keep fingers out of syringe slot while the pump is running to avoid injury.
- Always power off the pump before connecting or disconnecting the pump.

## 1.5 Power Supply

### 1.5.1 Power Supply for a Single Pump

SP4-D1 requires 24V DC power supply, provided through the pin 1 and pin 10 of DB-15 connector. The power supply for a single pump should meeting following requirements:

- Output voltage: 24V DC
- Output voltage tolerance:  $\pm 10\%$  maximum,  $\pm 5\%$  preferred.
- Output voltage regulation:  $\pm 1\%$  (within the allowed range of input voltage and load)
- Output current
  - $\geq 1.5A$  for power supplies with minimal capacitance
  - $\geq 850mA$  for power supplies with internal filter capacitance of at least 1000  $\mu F$  per amp of output current.
  - $\geq 850mA$  for power supplies with external filter capacitance of at least 1000  $\mu F$  per amp of output current (aluminum electrolytic capacitor preferred)
- Output voltage ripple: 50mV maximum at full load.
- Voltage turn-on and turn-off overshoot:  $< 2V$

To meet above requirements, the power supply must incorporate either linear or

switching regulation and must have adequate output filter capacitance. A current-limiting power supply is recommended. Current limiting above 1.0A is acceptable, assuming that no additional equipment is operated from the supply.

## 1.5.2 Power Supply for Multi-Pump

When a power supply is used to operate more than one SP4-D1 or other device, it must provide the total average current for all devices. The power supply and filter capacitance must satisfy the total peak input current for all devices.

For example, if the system has 6 sets of SP4-D1, and other equipment requiring 4A, then a 10A power supply is satisfactory. And the output filter capacitance in the power supply is at least 10,000uF:

$$6 \times 0.85 = 5.1\text{A}; 5.1 + 4 = 9.1\text{A} \text{ (choose a 10A power supply)}$$

If the power supply filter capacitance is less than 10,000uF, use either additional external capacitance or a 15A power supply.

$$6 \times 1.5 = 9.0\text{A}; 9.0 + 4 = 13\text{A} \text{ (choose a 15 power supply)}$$

In this example, it is assumed that all the pumps and other equipment will sometimes operate at the same time.

Inadequate filter capacitance or current can cause overvoltage transients and sags, and can create unnecessary ripple in SP4-D1. This can result in decreased component life. Additionally, it is possible for a regulated power supply to become unstable with certain loads and oscillate if filter capacitance is inadequate. Some forms of oscillation can cause failures in the SP4-D1. These issues can be avoided by using a proper power supply.

Consideration should also be given to the wiring of the SP4-D1 and any additional devices. Wiring should be of sufficient gauge for the current, and as short as possible. Unless otherwise required by safety requirements, the power supply lines to SP4-D1 should be 20AWG or heavier. For multiple SP4-D1, make sure the wire size and power supply are adequate for the total current. In the example of the 6 SP4-D1 above, use 18AWG wire if the units are daisy-chained. It is best if each pair is twisted or dressed together for the device to the supply.

Do not use a relay or switch contacts between the 24VDC supply and the SP4-D1.

## 2 Hardware Setting

This chapter includes below topics:

- Power Supply
- Communication Interface
- Control Board Setting
- SP4-D1 Valve Connector
- Installing Component
- Pump Mounting

### 2.1 Power Supply

SP4-D1 requires 24VDC power supply with current rating of at least 1.5A, provided through a DB-15 connector. It is recommended to use one power cable for every two pumps to provide noise immunity. Power cable should not be daisy-chained to more than two pumps.

Please refer to Chapter 1, “Product Introduction”, for more information.

### 2.2 Communication Interface

Each SP4-D1 has one external communication interface, which supports power supply and communication with pump.

Each pump has a unique address, refer to “Address Switch Setting” in this chapter, and Chapter 3, “Software Communication” for more information.

**Table 2-1. DB15 Connector Pin Definition:**

Pin	Function	Remarks
1	DC_24V	Power Supply+
2	TXD	RS232 Output data
3	RXD	RS232 Input data
4	COM	Logic ground for input and output
5	NC1	Reserved
6	NC2	Reserved
7	IN1	Input 1
8	IN2	Input 2
9	GND	Power and logic
10	GND	Power and logic
11	RS-485 A	RS-485 A
12	RS-485 B	RS-485 B

13	OUT1	Output 1
14	OUT2	Output 2
15	OUT3	Output 3

Figure 2-1 shows the pin position of the DB-15 connector on the control board. This is a male connector that requires a female connector on the mating cable.

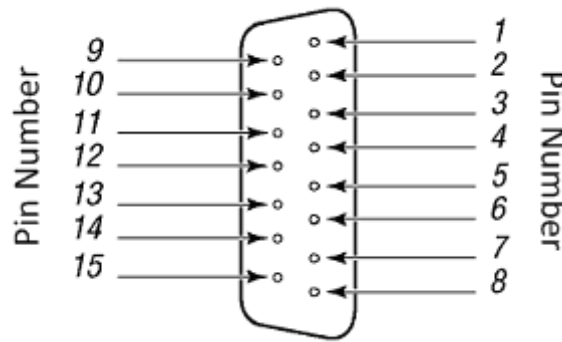

Figure 2-1 DB15 Pins

### Communication Interface

The computer or controller communicates with the SP4-D1 through RS232 or RS485 interface.

**Note: The RS232 interface does not support hardware handshaking and requires only three lines: RXD, TXD, and Signal Ground.**

Examples of cabling connections are shown in Figure 2-2 (RS232) and Figure 2-3 (RS485) in following pages.

**Note: Power off the pumps before connecting to or disconnecting from the bus.**

RS232 Multi-pump cabling

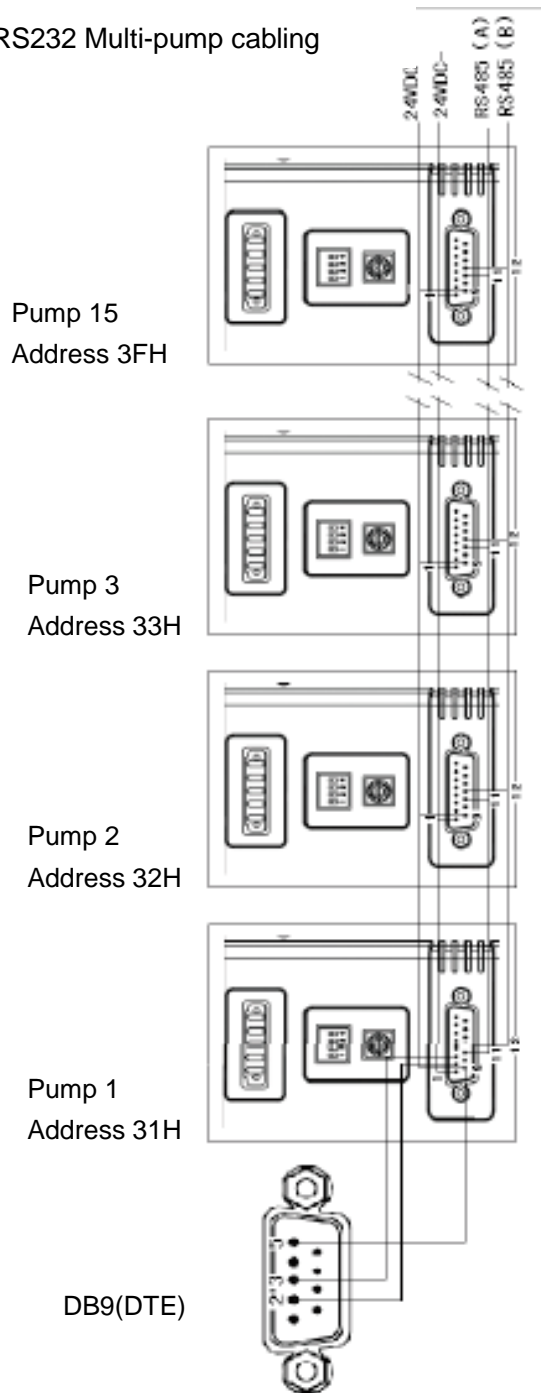
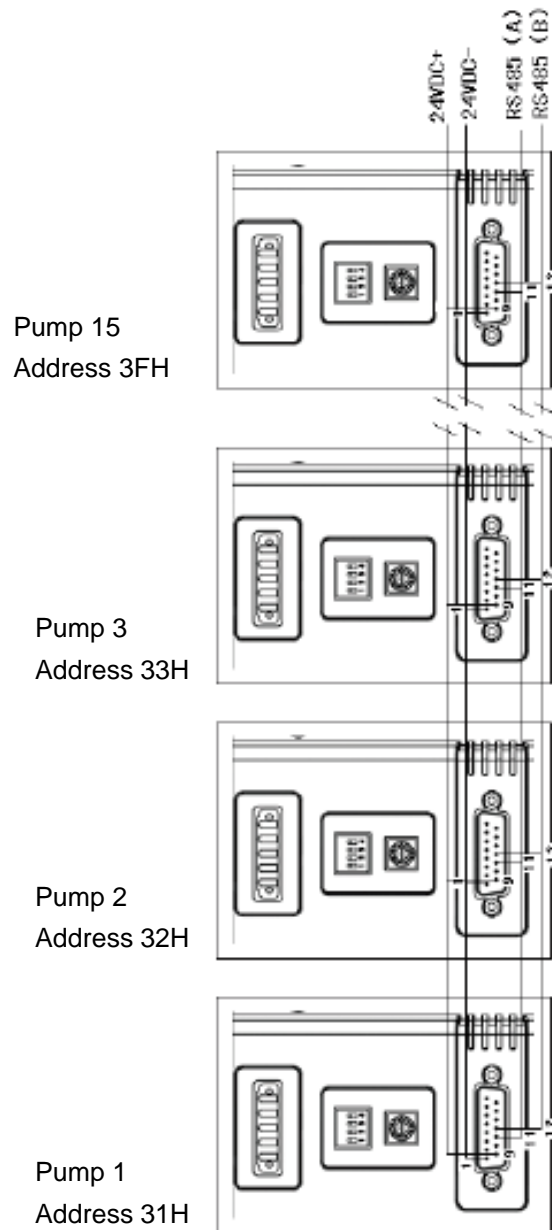

Figure 2-2 RS-232 Multi-pump Cabling

## RS485 Multi-pump cabling

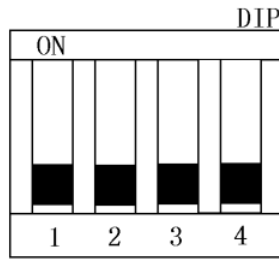

**Figure 2-3 RS-485 Multi-pump Cabling**

## 2.3 Control Board Setting

### 2.3.1 DIP Dial Switch Setting

DIP dial switch is used to set the different working modes and configurations. Refer to Figure 2-4 for the DIP dial switch setting and the corresponding working mode and configuration.



**Figure 2-4 DIP Dial Switch Setting**

DIP	Definition	ON	OFF
1	Protocol	Data Terminal (DT) protocol	OEM protocol
2	Baud Rate	38400 bps	9600 bps
3	Communication Interface	RS232	RS485
4	Stalling protection	Disable	Enable

**Note: Power off the pump when set the DIP switch.**

**DIP-1: Set protocol**

DIP-1 ON: Data Terminal (DT) protocol  
 DIP-1 OFF: OEM protocol (default setting)

**DIP-2: Set the baud rate**

DIP-2 ON: 38400bps  
 DIP-2 OFF: 9600bps (default setting)

**DIP-3: Set the communication interface**

DIP-3 ON: RS232  
 DIP-3 OFF: RS485 (default setting)

**DIP-4: Enable the stalling protection**

DIP-4 ON: Stalling protection is disabled  
 DIP-4 OFF: stalling protection is enabled (Default setting)

## 2.3.2 Address Switch Setting

Address switch (Figure 2-5) is located on lower of the pump back panel. It is used to set the unique address for each pump in the multi-pump system, allowing user to direct commands to specific pump. There are 16 positions (0-F) on the address switch. 15 positions (0-E) are valid pump addresses. F is for self-test function.

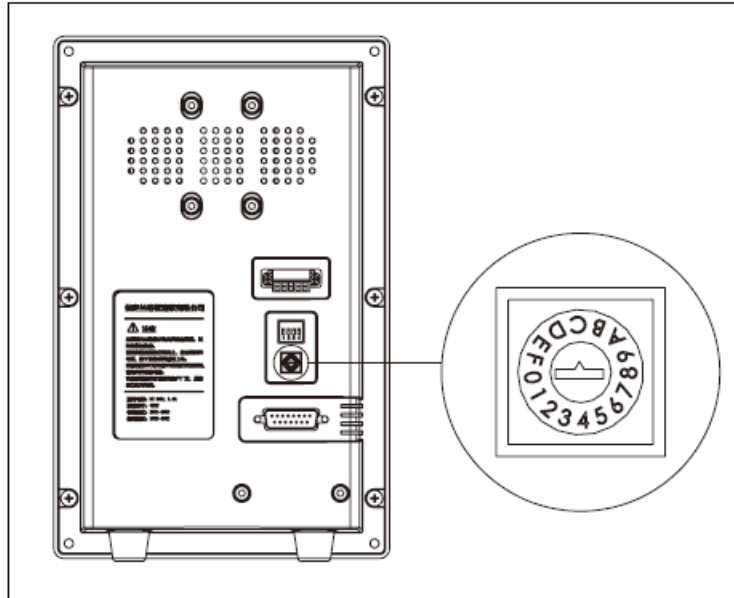

**Figure 2-5. Address Switch**

To set the address switch:

Power off the pump, then use a small flat head screwdriver and turn the switch in either direction to the desired position.

**Note: Restart the pump after re-setting the address switch.**

### **Self-test Function**

Set the address switch on the “F” position, the pump will run the self-test program when power on. Self-test causes the SP4-D1 to initialize, then cycle repeatedly through a series of plunger movements. If an error condition occurs, the pump stops moving.

**Caution: Always run liquid through the syringe. Failure to do so can damage the syringe seal.**

## **2.3.3 Input/Output**

SP4-D1 provides two auxiliary inputs (TTL level signal) and three auxiliary outputs (TTL gate signal) that can be accessed through the DB15 connector. The outputs are controlled by the [J] command.

The auxiliary inputs are located on pin7 and pin8 of the DB15 connector. They can be read back using report commands [?I]. Additionally, the inputs can be used to externally trigger a command sequence using the [H] command. Refer to Chapter 3 “Software Communication” for commands detail.



The auxiliary outputs are located on pin13, pin14 and pin15 of the DB15 connector. They can be read back using report commands [?J].

## 2.3.4 Solenoid Valve Control Interface

SP4-D1 provides terminals to connect external solenoid valves, then energize or de-energize the external solenoid valves by outputting 24VDC voltage (current 200mA) or not. The definition of the terminals is:

Terminal for Solenoid Valves

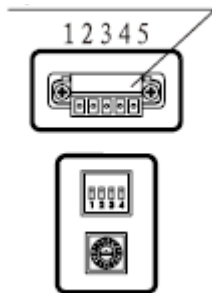

Terminal	Definition
1	COM for external solenoid valve
2	External solenoid valve 1
3	External solenoid valve 2
4	External solenoid valve 3
5	External solenoid valve 4

## 2.4 SP4-D1 Valve Connector

SP4-D1 does not has valves to switch the fluid paths. A valve connector is provided for external valve connection. The connector has 4 fluid paths. Each path has 2 ports with 1/4-28 UNF thread. Upper port is for tubing fitting, which can be connected to external valves. The lower port is for syringe.

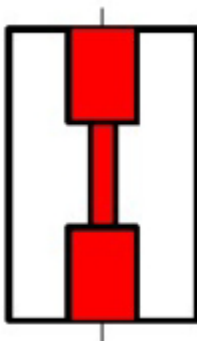

## 2.5 Installing Component

Refer to Chapter 5 “Maintenance” for the operation of component maintenance and replacement.

## 2.5.1 Install the Syringe

To install a syringe, follow below steps:

1. Unscrew the plunger lock screw.
2. Send [ZR] command to initialize the pump. Then send [A3000R] command to lower the plunger holder.
3. To install the syringe (as shown in Figure 2-6)
  - a Pull the syringe plunger down to the plunger holder, and insert the holder into the hole of the plunger.
  - b Put the gasket into the valve connector port, then screw the syringe into the valve connector port.
  - c Tighten the plunger lock screw to ensure the syringe plunger into place.

**Note: Make sure the gasket is put into the valve connector port and tighten the syringe. The gasket can be placed on the top of the syringe before screw the syringe. To prevent the gasket from falling off during screwing the syringe, a proper amount of silicone oil can be applied between the gasket and the syringe. When tightening the syringe, you should turn the knurled part of the metal connector of the syringe by hand. Do not turn the glass barrel directly to prevent personal injury from damage to syringe or broken glass. Make sure that the plunger lock screw is securely tightened.**

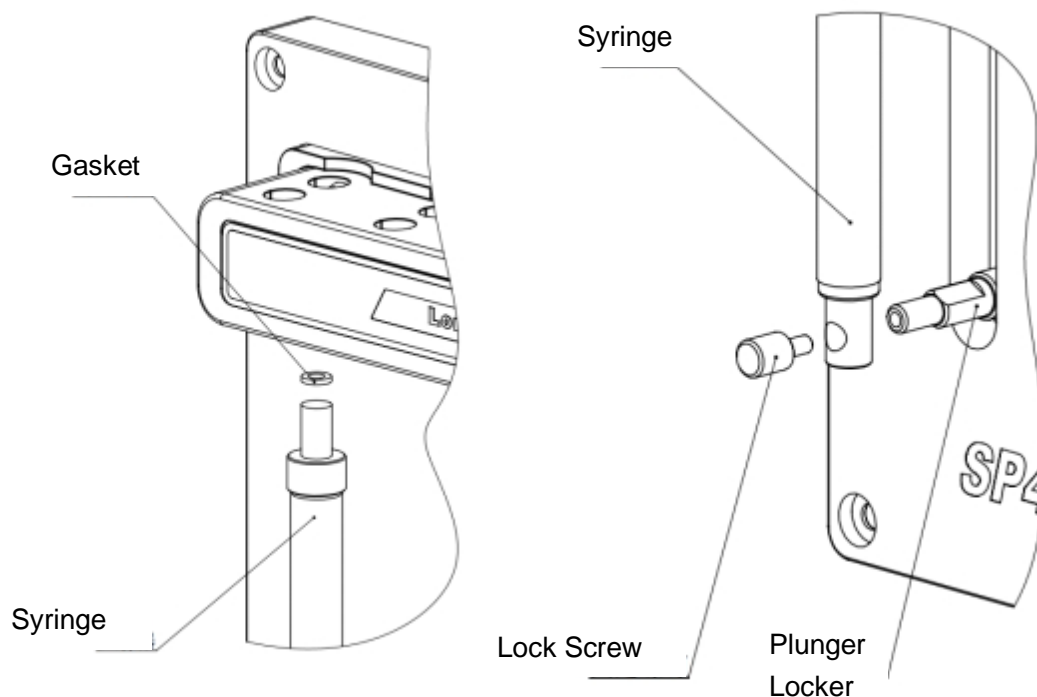

**Figure 2-6 Syringe Installing**

## 2.6 Pump Mounting

Numerous M4 mounting holes provide several mounting methods as below. Refer to Figure 2-7 for the mounting holes position.

- Mounting from the bottom
- Mounting from the top

**Note: Always mount the pump in an upright position. Failure to do so can cause problems in priming the system.**

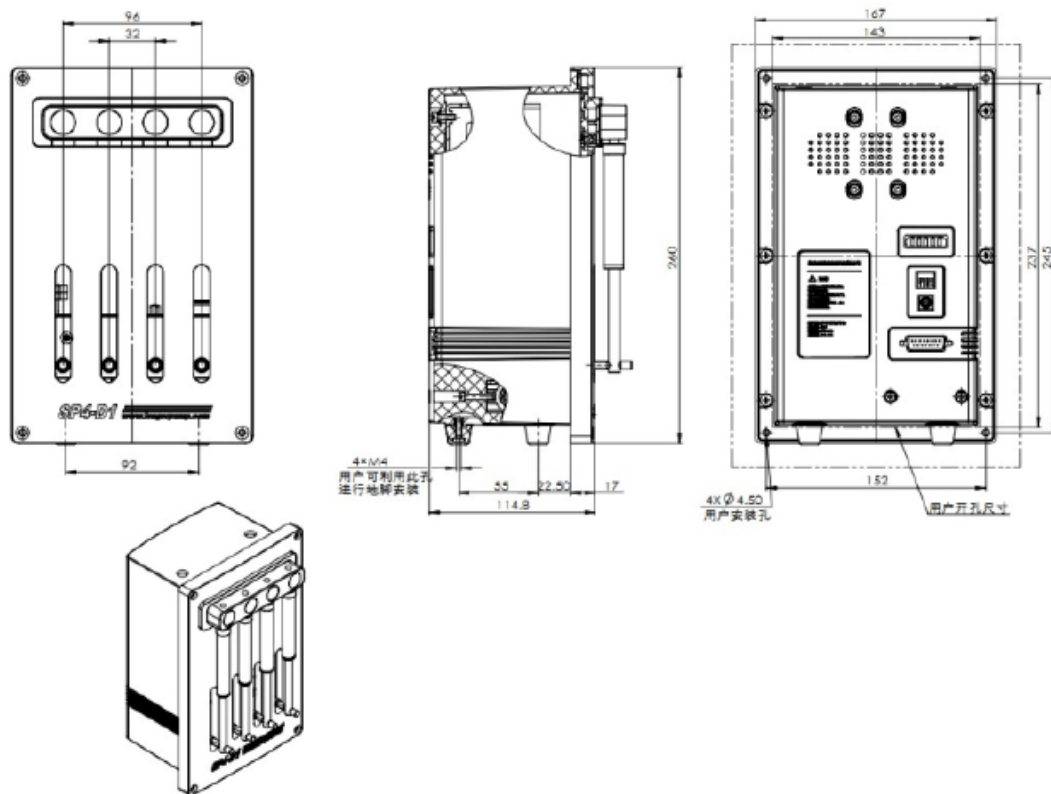

Figure 2-7 SP4-D1 Mounting Holes

## 3 Software Communication

This chapter describes how to communicate with the SP4-D1 through RS-232 or RS-485 interface.

This chapter includes below topics:

- Address Setting
- Communication Protocols
- Command Set
- Error Codes and Pump Status

## 3.1 Address Setting

As part of the communication protocol, an address for each pump must be specified. Each physical address set by address switch corresponds to one hexadecimal value. Refer to below table 3-1.

**Table 3-1 Address Scheme (Hex)**

Address (Hex)	Device
RS-232/RS-485	
30	Master address (master controller, PC, etc.)
31-3F	Pump address
5F	Broadcast address- all devices on the bus will operate according to the same command when using broadcast address.

For example: a pump with address switch (hardware address) set to position 0 is addressed as device “31h” in the RS-232 or RS-485 communication protocol. A pump with address switch (hardware address) set to position 1 is addressed as device “32h”, and so on.

In multi-pump configuration, PC or master controller can communicate with all pumps simultaneously by using “5F” (broadcast address), such as initializing all pumps at once. Each pump can be controlled independently by using “31h” to “3Fh”.

**Note: When using broadcast address, PC can't read pump's status and the pump can't answer the report commands. Must use specific address to read each pump status.**

## 3.2 Communication Protocol

Two communication protocols are available:

- OEM communication protocol
- Data Terminal (DT) protocol

The DT protocol can be run through an ASCII data terminal because no sequence numbers or checksums are used. Refer to “Using DT Protocol with Microsoft Windows” in this chapter for instruction.

**Note: Recommend to use the OEM protocol, which provides increased error checking.**

## 3.2.1 OEM Communication Protocol

OEM communication is a robust protocol. Table 3-2 describes each setting within the OEM communication protocol

**Table 3-2 OEM Protocol**

Parameter	Setting
<b>Frame Format</b>	
Baud rate	9600 or 38400 (set by DIP-2)
Data bits	8
Parity	None
Stop bit	1
<b>Command Message Format (Refer to “OEM Communication Protocol Command Format” for details)</b>	
1	STX(^B or 02h)
2	Pump address
3	Sequence number
3+n	Data block (length n)
4+n	ETX (^C or 03h)
5+n	Checksum
<b>Pump Answer Message Format (Refer to “OEM Communication Protocol Answer Format” for details)</b>	
1	STX(^B or 02h)
2	Master address (“0” or 30h)
3	Status code
3+n	Data block (length n)
4+n	ETX (^C or 03h)
5+n	Checksum

## OEM Communication Protocol Command Format

The command characters are described as below:

STX is the beginning of the message, checksum (character after the ETX) is the end of the message.

**STX(^B or 02h):** STX character indicates the beginning of a message

**Pump Address:** “0”~”E”(31h~3Fh)

**Sequence Number:** Fixed value of“1”(31h)

**Data Block(length n):** The data block consists of the commands and values sent to the pump, using ASCII code, most significant byte first.

Example: A1000: 5 bytes, ASCII Code: 41 31 30 30 30

**ETX(^C or 03h):** ETX character indicates the end of a command

**Checksum:** Checksum is the last byte of the message string. The 8-bit checksum is the bit XOR of all bytes (from STX to ETX and including STX and ETX).

## OEM Communication Protocol Answer Format

The answer characters are described as below:

Only the unique answer characters are listed in this section. For the same characters as command message, please refer to “OEM Communication Protocol Command Format”.

**Master Address:** “0” (30h)

**Status and Error Codes:** Pump status and error conditions. Refer to “Error Codes and Pump Status” in this chapter.

### 3.2.2 DT (Data Terminal) Protocol

**Table 3-3 DT Protocol**

Parameter	Setting
<b>Frame Format</b>	
Baud rate	9600 or 38400 (set by DIP-2)
Data bits	8
Parity	None
Stop bit	1
<b>Command Message Format (Refer to “DT Communication Protocol Command Format” for details)</b>	
1	“/” ( 2Fh)
2	Pump address
2+n	Data block (length n)
3+n	Carriage return ([CR] or 0Dh)
<b>Pump Answer Message Format (Refer to “DT Communication Protocol Answer Format” for details)</b>	
1	“/” ( 2Fh)
2	Master address ( “0”or 30h)
3	Status character

3+n	Data block (length n)
4+n	ETX (03h)
5+n	Carriage return (0Dh)
6+n	Line feed (0Ah)

## DT Communication Protocol Command Format

The command characters are described as below:

“ / ”: “/” character indicates the beginning of a message

**Pump Address:** “0”~”E”(31h~3Fh)

**Data Block(length n):** The data block consists of the commands and values sent to the pump, using ASCII code, most significant byte first.

Example: A1000: 5 bytes, ASCII Code: 41 31 30 30 30

**Carriage return (0Dh):** 0Dh indicates the end of the message.

## DT Communication Protocol Answer Format

The answer characters are described as below:

Only the unique answer characters are listed in this section. For the same characters as command message, please refer to “DT Communication Protocol Command Format”.

**Master Address:** “0” (30h)

**Status and Error Codes:** Pump status and error conditions. Refer to “Error Codes and Pump Status” in this chapter.

**Data Block (length n):** This is the response from all Report commands with the exception of the [Q] command.

**Carriage Return(0Dh)/ Line Feed(0Ah):** This character terminates the reply message.

### 3.2.3 Using DT Protocol with Microsoft Windows

SP4-D1 can be controlled in DT protocol mode directly from the Microsoft Windows terminal accessory.

To communicate with the SP4-D1 using Windows 95/98/NT/2000/XP, follow these steps:

1. Connect the SP4-D1 to a communication port on the PC, first select the **Start Programs/Accessories/Communications Hyperterminal** menu and choose **Run**.
2. In the Run dialog box, type **Hypertrm.exe**. The Connection Description dialog box appears.
3. Enter a name for the connection and select an icon, then click **OK**. The Phone Number dialog box appears.
4. Select the following in the fields provided:  
Connect using: Direct to <communication port> (usually COM1 or COM2 depending on how the hardware is set up)  
Click **OK**. The COM Properties dialog box appears.
5. Select the following in the fields provided:  
Bits per second: 9600  
Data bits: 8  
Parity: None  
Stop bits: 1  
Flow control: None  
Click **OK**.
6. Select the **File** menu and choose **Properties**. The Properties dialog box appears.
7. Select the **Settings** tab, and enter or select these options:
  - Function, arrow, and Control keys act as:
    - Select "Terminal keys"
  - Emulation:
    - Select "Autodetect"
    - Enter "500" in Backscroll buffer lines
  - Click the **ASCII Setup** button. The ASCII Setup dialog box appears.
8. Enter or select these options:
  - Select "Send line ends with line feed"
  - Select "Echo typed characters locally"
  - Enter a Line delay of "0"
  - Enter a Character delay of "0"
  - Select "Wrap lines that exceed terminal width"
9. Click **OK** to close the ASCII Setup dialog box, then click **OK** to close the Properties dialog box.
10. Set the pump address. Factory default address is "0".
11. Set the DIP switch: DIP-5 and DIP-6 are set OFF for 9600 baud rate and RS-485 interface.
12. Power on the pump and initialize it by typing /1ZR and pressing **Enter**.

Refer to "Command Set" in this chapter for pump option details.



## 3.3 Command Set

SP4-D1 has a robust command set allowing a wide range of parameters to be defined by the user. Many of the commands have default values. But the default values may not be the optimum values for specific application.

For a quick glance at summary of all commands, refer to Appendix E, "Command Quick Reference".

When problems are detected, SP4-D1 sends an error code. Refer to "Error Codes" at the end of this chapter for details.

### 3.3.1 Command Execution Guidelines

To use the commands properly, pay attention to :

- Except Report commands and [Q] command, all commands must be followed by a [R] command.
- Pump can accept a single command or multiple command string.

Example:

- Single command: [A1000R], moves the plunger to position 1000.

- Command strings such as [IA1000OA0R] energize the external solenoid valve to connect the input port to the common port (if the valve input port is energized to open), moves the plunger to position 1000, then de-energize the external solenoid valve to connect the output port to the common port (if the valve output port is de-energized to open), and finally returns the plunger to position 0.

- The pump command buffer holds a maximum of 64 bytes. If a command (string) is sent without the [R] command, it is placed into the buffer without being executed. If a second command is sent before the first command is executed, the second command overwrites the first command.
- When a command (string) is executing, new commands (strings) are not accepted until the sequence is completed. Exceptions to this rule include Terminate (refer to "T Terminate Command" in this chapter), Report commands and [Q] command.
- When a command is sent, the pump answers immediately. If an invalid command has been sent in a command string, the pump reports an error

immediately. If there was an invalid parameter in the command, the pump will execute up to the invalid parameter, then stop. And the error will be read back to the host computer when receiving the [Q] command.

- Always run liquid through the syringe when issuing a Move command. Failure to do so may damage the syringe seal.
- Keep fingers out of the syringe slot while the pump is running. Failure to do so can result in injury.

#### Command Syntax

The syntax for each command:

<n>	Parameter
0..1000	Range of parameter allowed
(n)	Default value

**Note: In command examples, content in [ ] only indicates the commands and should not be sent as part of the command strings.**

### 3.3.2 Control Commands

#### R Execute Command (String)

[R] command tells the pump to execute the new or previously loaded but unexecuted command (string).

Commands (strings) containing [R] at the end will execute immediately. If the command (string) is sent without [R], it is placed in the command buffer.

Sending the [R] alone, pump will execute the last unexecuted command in command buffer. Sending another [R], the pump will not repeat the command (string).

#### X Execute Last Executed Command (String)

[X] command repeats the last executed command (string)

#### G<n> Repeat Command

[G] command repeats a command (string) the specified number of times. The syntax for this command is:

[G<n>], where <n>=0-30000 0=repeated until a Terminate command [T] is

issued.

Example: [gA1000A0G10R] moves the plunger to position 1000, then back to position 0. This sequence is repeated 10 times.

### g Mark the Start of a Repeat Sequence

[g] command is used in conjunction with the [G] command. [g] indicates the beginning of a repeat sequence within a command string.

Example: [A0gP50gP100D100G10G5R], the process as below:

Command	Description
A0	Move the plunger to position 0
g	Outer loop start
P50	Move the plunger down 50 steps
g	Inner loop start
P100	Move the plunger down 100 steps
D100	Move the plunger up 100 steps
G10	Inner loop, repeat 10 times
G5	Outer loop, repeat 5 times.
R	Execute the command string

**Note: if <n>=0, endless loop, the sequence is repeated until a Terminate command [T] is issued.**

### M<n> Delay Command

[M] command is used to delay the execution of a command in milliseconds. This command is typically used to allow time for liquid in pump and tubing to stop oscillating, thereby enhancing precision. The syntax for this command is:

[M<n>], where <n>=5..30,000 milliseconds

## H<n> Halt Command

[H] command is used within a command string to halt execution of the string. To resume execution, a [R] command or TTL trigger signal must be sent.

The syntax for this command is:

[H<n>]

Two TTL inputs are available, input 1 (DB15 pin7) and input 2 (DB15 pin8). Control the execution as below:

<n>=0 Waits for [R] or rising edge of either input 1 or 2 to resume the execution

<n>=1 Waits for [R] or rising edge of input 1 to resume the execution

<n>=2 Waits for [R] or rising edge of input 2 to resume the execution

**Note: If the value of <n> is not specified, <n> defaults to 0.**

## T Terminate Command

[T] command is used to terminate the plunger movement in progress ([A] [P] [D] [H] [M])

**Note: [T] command can't terminate the Valve Command.**

[T] command will terminate both single commands and command strings.

When a plunger move is terminated by [T] command, lost steps may happen. Reinitialization is recommended following termination. If the command was terminated due to a problem or error, the pump must be reinitialized.

## J<n> Outputs

[J] command sets the output (TTL signal)

The syntax is:

[J<n>], Where <n>=0..7(0 is the default)

DB15 provides 3 outputs, output 1 (pin13), output 2 (pin14) and output 3 (pin15). They are controlled as shown in below table:

**Table 3-4**

SP4-D1 Command	Output 3 (Pin 15)	Output 2 (Pin 14)	Output 1 (Pin 13)
J0	0	0	0
J1	0	0	1
J2	0	1	0
J3	0	1	1
J4	1	0	0
J5	1	0	1
J6	1	1	0
J7	1	1	1

(0=High Level, 1= Low Level)

Note: Initialization command will not reset the <n> of [J] command to default value. The <n> of [J] command will be the default value when power off the pump.

#### **h Dynamic Halt Command**

When pump receives [h] command, the pump will stop current command (string) and wait for dynamic recovery command [r] to continue current command (string), or terminate command [T] to terminate current command (string).

#### **r Dynamic Recovery Command**

[r] command is used to continue the command (string) stopped by [h] command.

### **3.3.3 Initialization Commands**

#### **Initialization Commands**

Z<n> command initializes the plunger to “home” position. Move the plunger down 200 steps, then move the plunger upwards to the position of optical coupler, which is the position 0. The parameter <n> is for the plunger speed during the initialization. 1 to 7 corresponds to speed V100 to V700. The default value 0 corresponds to speed V800. Refer to below description on the parameters:

**Table 3-7.**

Command	Parameter/Value	Description
Z	<n>=0 (default) <n>=1~7	Initializes the plunger

### 3.3.4 Plunger Movement Command

#### **A<n> Absolute Position**

[A] command moves plunger to the absolute position <n>, where <n>=0..1000.

For example: [A300R] moves plunger to the absolute position 300.

#### **P<n> Relative Pickup**

[P] command moves plunger down the number of steps commanded. The new absolute position= previous absolute position + <n>, where <n>=0..1000.

For example:

The plunger is at position 0. [P300R] moves plunger down 300 steps to absolute position of 300. Then [P600R] moves plunger down 600 steps to absolute position of 900.

The [P] command will return error 3 (invalid parameter) if the final plunger position>1000.

#### **D<n> Relative Dispense**

[D] command moves plunger upward the number of steps commanded. The new absolute position= previous absolute position - <n>, where <n>=0..1000.

For example:

Plunger is at position 1000. [D300R] moves the plunger up 300 steps to an absolute position of 700.

[D] command will return error 3 (invalid parameter) if the final plunger position would be less than 0.

#### **P Quick Rinse**

The plunger will move twice in full stroke.

### 3.3.5 Valve Command

#### **I Energize the External Solenoid Valve**

[I] command to energize the solenoid valve by outputting 24VDC voltage (current≤200mA) through the control interface.

The syntax is:

[I<n>], Where <n>=0..8(0 is the default)

Meaning of parameter <n>:

Command & Parameter	Valve 1	Valve 2	Valve 3	Valve 4
I[0]	Energize	Energize	Energize	Energize
I[1]	Energize			
I[2]		Energize		
I[3]			Energize	
I[4]				Energize
I[5]	Energize	Energize		
I[6]		Energize	Energize	
I[7]			Energize	Energize
I[8]	Energize			Energize

#### O De-energize the External Solenoid Valve

[O] command to de-energize the solenoid valve by no voltage output.

When the pump is powered on or after initialization, no voltage output through the control interface by default.

The syntax is:

[O<n>], Where <n>=0..8(0 is the default)

Meaning of parameter <n>:

Command & Parameter	Valve 1	Valve 2	Valve 3	Valve 4
O[0]	De-energize	De-energize	De-energize	De-energize
O[1]	De-energize			
O[2]		De-energize		
O[3]			De-energize	
O[4]				De-energize
O[5]	De-energize	De-energize		
O[6]		De-energize	De-energize	
O[7]			De-energize	De-energize
O[8]	De-energize			De-energize

### 3.3.6 Set Command

Set commands are used to control the speed of the plunger and set the backlash compensation.

#### **K<n> Backlash Steps**

[K] command sets the number of backlash steps. The syntax is:

[K<n>], where <n>=0..50 (when parameter <n> is omitted, means backlash step is 0)

When no [K<n>] command sent to the pump, the default backlash step is 30 steps.

Note: When the plunger drive motor reverses direction, the plunger will not move until the backlash due to mechanical clearance within the system is compensated. To provide this compensation, during aspiration, the plunger moves down additional steps, then backs up the set number of backlash steps. This ensures that the plunger is in the correct position to begin a dispensing move. Note that, during this operation, a small volume of fluid will discharge from the valve connector port.

#### **V<n> Set Plunger Speed**

[V] command sets the plunger speed. The bigger the parameter <n> is, the faster the plunger move. The syntax for this command is:

[V<n>], where <n>=1...800 (default speed is same as the initialization speed)

Linear speed of plunger movement=  $60\text{mm} \cdot n / 2000\text{s}$

Example:

If set the speed as V<800>, then the linear speed of the plunger movement is

$60\text{mm} \cdot 800 / 2000\text{s} = 60\text{mm} / 2.5\text{s} = 24\text{mm/s}$

If set the speed as V<1>, then the linear speed of the plunger movement is

$60\text{mm} \cdot 1 / 2000\text{s} = 60\text{mm} / 2000\text{s} = 0.03\text{mm/s}$

### 3.3.7 Report Commands

#### **? Report Absolute Plunger Position**

[?] command reports the absolute target position of the plunger in steps, returns [0...1000].

#### **?V Report Pump Speed**

[?V] command reports the pump speed, returns [1...800]Hz.



## F Report Command Buffer Status

[F] command reports the command buffer status. If the buffer is empty, the status code is 96. If the buffer is not empty, the status code is 64. If a program string is sent to the pump without an [R] command, the string is loaded into the buffer and the buffer status becomes status 64. An [R] command will then execute the command stored in the buffer.

## ?I Report Status of Auxiliary Input 1 (DB15, Pin7) and Input 2 (DB15, Pin8).

Status	Input 1 (Pin 7)	Input 2 (Pin 8)
0	Low	Low
1	Low	High
2	High	Low
3	High	High

## 3.3.8 Error Codes and Pump Status

Q command reports the error codes and pump status (refer to table 3-12.)

Table 3-12: Error Code and Pump Status

Status Byte	Hex # if Bit 5 =		Dec # if Bit 5 =		Error Code	Error description
	7 6 5 4 3 2 1 0	0	or 1	0	or 1	
0 1 X 0 0 0 0 0	40h	60h	64	96	0	No Error
0 1 X 0 0 0 0 1	41h	61h	65	97	1	Initialization Error
0 1 X 0 0 0 1 0	42h	62h	66	98	2	Invalid Command
0 1 X 0 0 0 1 1	43h	63h	67	99	3	Invalid Parameter
0 1 X 0 0 1 0 0	44h	64h	68	100	4	Invalid Command String
0 1 X 0 0 1 0 1	45h	65h	69	101	5	Reserved
0 1 X 0 0 1 1 0	46h	66h	70	102	6	Reserved
0 1 X 0 0 1 1 1	47h	67h	71	103	7	Device Not Initialized
0 1 X 0 1 0 0 1	49h	69h	73	105	9	Plunger Overload
0 1 X 0 1 0 1 0	4Ah	6Ah	74	106	10	Reserved
0 1 X 0 1 0 1 1	4Bh	6Bh	75	107	11	Reserved
0 1 X 0 1 1 1 1	4Fh	6Fh	79	111	15	Reserved

[Q] command reports error codes and pump status (ready or busy). The user should send a [Q] command before sending a program string or individual command to ensure that the pump has completed the previous command successfully.

Note: [Q] command is the only valid methods for obtaining status.

The response to the [Q] command (the status byte) provides two items of information: Pump status (bit 5) and error code (bits 0-3).

### Status Bit

Bit 5 is the status bit. It indicates when the pump is busy or not busy. The designations for bit 5 are listed below:

**Table 3-13.**

Status Bit 5	Description
X=1	Pump is ready to accept new commands
X=0	Pump is busy and will only accept Report commands, [Q] command and Terminate command.

In response to Move commands ([A], [P] and [D]), the [Q] command reports that the pump is busy. Commands addressed to multiple pumps at once can't be used to obtain pump status. Pumps must be queried separately.

**Note:** Although the answer message for other commands contains a status bit, it should not be used for determining pump status. A [Q] command is the only valid method to determine if the pump is busy. The error information in the status byte of the answer message is always valid.

### Error Codes

Error codes describe problem conditions that may be detected in the SP4-D1. Error codes are returned in the least significant 4 bits of the status byte. If an error occurs, the pump stops executing commands, clears the command buffer, and inserts the error code into the status byte.

Some errors continue to appear, such as syringe overloads, until they are cleared by the Initialization command. On a plunger overload, the device will not execute another valve or plunger Movement command until it is reinitialized. The last error has precedence in the status byte. For example, if a plunger overflow occurs, an error 9 results. If the next command causes an error 3, the status byte reflect the error 3 (invalid parameter).

**Table 3-14.**

Error Code	Description
0(00h)	Error Free Condition.
1(01h)	Initialization error. This error occurs when the pump fails to initialize.
2(02h)	Invalid Command. This error occurs when an unrecognized command is issued. Correct the command and operation will continue normally.

3(03h)	Invalid Parameter. This error occurs when an invalid parameter <n> is given with a command. Correct the parameter and pump operation will continue normally.
4(04h)	Invalid Command String. This error occurs when invalid command string is received.
5(05h)	Reserved.
6(06h)	Reserved.
7(07h)	Device Not Initialized. This error occurs when the pump is not initialized. To clear the error, initialize the pump.
9(09h)	Plunger Overload. This error occurs when movement of the syringe plunger is blocked by excessive backpressure. The pump must be reinitialized before normal operation can resume. This error can only be cleared by reinitializing the pump.
10(0Ah)	Reserved.
11(0Bh)	Reserved.
15(0Fh)	Reserved.

## Error Types

The pump handles errors differently, depending on the error type.

### Immediate Errors

These include “Invalid Command” (error 2), “Invalid Parameter” (error 3), “Invalid Command String” (error 4). After the command is sent, the answer message immediately returns an error. Once a valid command is sent, the pump will continue to function normally.

### Initialization Errors

These include “Initialization Error” (error 1) and “Device not Initialized” (error 7). If the pump fails to initialize or if an Initialization command has not been sent, subsequent commands will not be executed.

To ensure that the pump initializes successfully, send a [Q] command after the Initialization command.

- If the [Q] command indicates both a successful initialization and that the pump is ready, subsequent Move commands can be sent.
- If the [Q] command indicates the pump has not been initialized, the pump must be reinitialized until the [Q] command indicates successful initialization.
- If initialization is not successful, a “Device Not Initialized” error is returned as soon as the next Move command is sent. A successful reinitialization must be

executed before subsequent commands can be sent.

### **Overload Errors**

These include the “Plunger Overload” (error 9). If the pump returns either a plunger overload, the pump must be reinitialized before continuing. If a successful initialization has not occurred, an initialization error is returned.

#### **Error Reporting Examples**

[A4000R] Returns “Invalid Parameter” error immediately. The error code will not be cleared but will be overwritten after receiving a new command.

[A1000A3500R] Returns “Invalid Parameter” error immediately.

[X1000R] Returns an “Invalid Command” error immediately. The pump status is “Not Busy”.

[A1000x1000R] Returns an “Invalid Command” error immediately. The pump is “Not Busy”.

## **4 Setting Up the SP4-D1 for Your Application**

The SP4-D1 device is designed for precision pumping across various hardware and fluid systems. The performance of the SP4-D1 in any specific application is influenced by factors such as fluid viscosity, aspiration and dispense speeds, and system geometry (including syringe size, tubing inner diameter, and valve inner diameter). The following section provides a detailed description of the hardware, fluid, and pump control parameters that need to be evaluated and optimized to manage these interdependencies for achieving optimal pump performance.

### **4.1 Glossary**

#### **Air Gap**

A small volume of air at the end of the output tubing or sandwiched between two fluids in the pump system tubing. Air gaps may be created by aspirating air (programmed air gaps) or by the spring action of the fluid system (inertial air gaps).

#### **Aspirate/Dispense Tubing**

Connects the valve ports (1/4-28 thread) to a sample source and destination. To ensure good breakoff, aspirate/dispense tubing tends to have a smaller ID than reagent tubing, and a necked-down or tapered end.

#### **Backlash**

Mechanical play in the syringe drive created by accumulated mechanical clearances. When plunger reverses, to ensure the accuracy, clearance compensation can be set.

**Backpressure**

The pressure which must be exceeded to move fluid through tubing. Backpressure is created by a combination of fluid inertia and friction.

**Breakoff**

Describes how the last droplet of fluid exits the end of the output tubing following a dispense. Rapid or sharp breakoff means that the droplet exits cleanly with high inertia.

**Breakup**

Undesired air gaps created by overly rapid aspiration.

**Carryover**

Contamination of a volume of fluid by residual fluid from a previous aspiration or dispense. Carryover causes variability in final volume and concentration.

**Cavitation**

Formation of air bubbles due to rapid pressure changes. Often caused by aspirating fluid into the syringe too quickly.

**Dilution effect**

Reduction in sample or reagent concentration, caused by contact with system fluid or residual fluid from a previous aspiration or dispense.

**I.D. (Inner Diameter)**

Diameter of the constraining wall of a fluid path.

**Priming**

Completely filling the pump tubing and syringe with bubble-free fluid to allow sustained, reproducible pumping action. The air in an unprimed line acts as a spring, adversely affecting accuracy and precision.

**Reagent Tubing**

Connects the valve input port (1/4-28 thread) to a reagent source. Reagent tubing is used to fill the pump syringe; it tends to have a larger I.D. than aspirate/dispense tubing, and a blunt-cut end which extends into the reagent.

**System Fluid**

A fluid used to prime the pump system that does not act as sample or reagent.

Typically the system fluid is de-ionized water or a wash buffer and is isolated from sample or reagent fluid by an air gap to avoid intermixing.

## 4.2 Optimizing SP4-D1 Performance

**Note: Run the pump only in the upright position. Do not move the syringe plunger without first wetting or priming the pump.**

For command details, refer to Chapter 3”Software Communication”

To optimize SP4-D1 performance, follow these steps:

### 1 Check chemical compatibility

Check the chemical compatibility chart in Appendix C, “Chemical Resistance Chart”, to determine if the fluids in your application are compatible with the SP4-D1 syringe and valve connector materials. If not, a system fluid is required. Complete the optimization procedure with the fluids you will use in your final system.

Note that the system fluid is used to prime the syringe and tubing from inlet to outlet. After the tubing is primed (and before any sample or reagent is aspirated), an air gap must be taken into the aspirated/dispense tubing to separate the system fluid from subsequently aspirated sample or reagent. Air gaps should be aspirated slowly to avoid break-ups, and the air gap volume should be one-tenth the volume of the aspirated fluid- or at least 10uL- to avoid any dilution effect. Similar air gaps should separate each aspirated fluid when performing multiple aspirates with no intervening dispenses, in order to prevent premature mixing and/or contamination. In addition, the aspirate/dispense tubing must be long enough to hold the total aspirate volume without coming in contact with the valve connector or syringe.

### 2 Select syringe size

Determine your volume and flowrate requirements. Select a syringe that accommodates the smallest and largest volumes to be dispensed without refill, as well as the desired flowrate (refer to Flowrate Ranges). While smaller syringes allow better accuracy and precision, a larger syringe allows more aliquots when multiple aspirations or multiple dispenses are required, and they allow better breakoff and longer seal life.

**Table 4-1 Flowrate Ranges**

Syringe Size	Minimum Flowrate	Maximum Flowrate
50uL	1.5 uL/min	1.2 mL/min
100uL	3 uL/min	2.4 mL/min

250uL	7.5 uL/min	6 mL/min
500uL	15 uL/min	12 mL/min
1mL	30 uL/min	24 mL/min
2.5mL	75 uL/min	60 mL/min
5mL	150 uL/min	120 mL/min

### 3 Select tubing

In tubing selection, the general rule is that smaller syringes work best with smaller I.D. tubing and larger syringes with larger I.D. tubing. The most valves have internal I.D. of 1/16". For aspirate/dispense tubing a thermal-drawn tip or tapered tip is most common, providing good breakoff and excellent accuracy and precision for most applications. A necked-down tip may be used when aspirating very small volumes of sample, i.e., 1-5uL. A blunt-cut tip is better suited for large volume applications. For tubing recommendations, refer to Table 4-2, Tubing Recommendations.

**Table 4-2 Tubing Recommendations**

SP4-D1 Applicable Tubing		
Part No.	Description	Length
008T16-050-20	1.6mm (1/16") O.D. x 0.5mm (.02") I.D.	20m
008T16-050-200	1.6mm (1/16") O.D. x 0.5mm (.02") I.D.	200m
008T16-100-20	1.6mm (1/16") O.D. x 1.0mm (.039") I.D.	20m
008T16-100-200	1.6mm (1/16") O.D. x 1.0mm (.039") I.D.	200m
008T32-150-10	3.2mm (1/8") O.D. x 1.5mm (.059") I.D.	10m
008T32-150-100	3.2mm (1/8") O.D. x 1.5mm (.059") I.D.	100m

### 4 Make pump connection

Connect power and communication cables to the pump, install syringe and tubing. Place the end of the input tubing in a reservoir of particle-free fluid, place the end of the output tubing in a waste reservoir.

### 5 Check communication to the pump

- a) Open the pump application program.
- b) Send the command [Z2R] to initialize the pump.

Possible errors:

No response. Check for loose or incorrectly connected cables, or connection to the wrong computer COM port. Retry.

## 6 Initialize the pump and set initialization speed

Send the command [ZR] to initialize the pump. Successful initialization will move the syringe plunger to the position 0 (fully dispensed) and return a Ready status.

## 7 Prime the syringe

a) Send the command [IA1000OA0R] to pull fluid through the solenoid valve input port (if the valve input port is energized to open) and into the syringe, then dispense the fluid through the valve output port (if the valve output port is de-energized to open).

b) Inspect the pump tubing and syringe for bubbles and re-prime until all bubbles are completely gone.

If bubbles remain after several priming strokes, disassemble the syringe and clean it with alcohol. Also check to ensure the fittings are tight and the syringe is tight within the valve connector port.

c) Re-prime.

Possible errors: Error 9 (plunger overload). Refer to step 8.

## 8 Check aspirate/dispense

Send the command [IA1000OA0R] to aspirate a full syringe stroke (1000 steps) from solenoid valve input and dispense it to solenoid valve output (if the valve is energized to open the input, and de-energized to open the output). Successful execution will move the syringe plunger to position 1000 then back to position 0, then it will return a Ready status.

Possible errors:

Error 9 (plunger overload). The stepper motor is unable to move the syringe plunger, probably because of excessive backpressure caused by excessive flowrate, narrow tubing I.D., or valve or tubing blockage. Note whether the error occurred during aspiration or dispensing. To differentiate between blockage and flowrate limitation, reduce syringe plunger speed by sending the command [V800IA1000OA0R]. Repeat with decreasing plunger speed (decrease V\_ value) until the pump aspirates and dispenses successfully.



## 4.3 Helpful Hints

To maintain pump performance, keep the following in mind when operating the pump:

- Wipe up all spills immediately.
- Pumping cold fluids may cause leaks, the result of differing coefficients of expansion of PTFE and glass. Leaks may occur when pumping fluids that are at or below 15°C.
- Before pumping any organic solvent, please refer to the Chemical Resistance Chart in Appendix C. Using organic solvents may reduce tubing and seal life.

## 5 Maintenance

Although required maintenance may vary with your application, the following procedures are recommended for optimal performance and maximum life of the SP4-D1.

Perform maintenance tasks in these intervals:

- daily
- weekly
- periodically

### 5.1 Daily Maintenance

To ensure proper operation of the SP4-D1, perform these tasks daily:

- Inspect the pump for leaks, and correct any problems.
- Wipe up all spills on and around the pump.
- Flush the pump thoroughly with distilled or deionized water after each use and when the pump is not in use.

**Note: Do not allow the pump to run dry for more than a few cycles.**

### 5.2 Weekly Maintenance

The fluid path of the SP4-D1 must be cleaned weekly to remove precipitates such as salts, eliminate bacterial growth, and so on. Any of the three following cleaning procedures can be used:

- Weak detergent
- Weak acid and base
- 10% bleach

The procedures using these solutions are described in the following sections.

### **5.2.1 Weak Detergent Cleaning**

To clean the pump with weak detergent, follow these steps:

- 1 Prime the pump with a weak detergent solution (e.g., 2% solution of CONTRAD®, RoboScrub, or flo-kleen) and allow the solution to remain in the pump with the syringe fully lowered for 30 minutes.
- 2 After the 30 minutes period, remove the reagent tubing from the detergent and cycle all the fluid from the syringe and tubing into a waste container.
- 3 Prime the pump a minimum of 10 cycles with distilled or de-ionized water. Leave the fluid pathways filled for storage.

### **5.2.2 Weak Acid-Base-Sequence Cleaning**

To clean the pump with weak acid and base, follow these steps:

- 1 Prime the pump with 0.1N NaOH and allow the solution to remain in the pump for 10 minutes with the syringes fully lowered.
- 2 Flush the pump with distilled or de-ionized water.
- 3 Prime the pump with 0.1N HCl, and allow the solution to remain in the pump for 10 minutes with the syringes fully lowered.
- 4 After a 10 minutes period, remove the reagent tubing from 0.1N HCl solution and cycle all the fluid from the syringes and tubing into a waste container.
- 5 Prime the pump a minimum of 10 cycles with distilled or de-ionized water.

### **5.2.3 10% Bleach Cleaning**

To clean the pump with 10% bleach, follow these steps:

- 1 Make a solution of 10% bleach by adding one part of commercial bleach to nine parts of water.
- 2 Prime the pump with the 10% bleach and allow the solution to remain in the pump with the syringes fully lowered for 30 minutes.
- 3 After the 30 minutes period, remove the reagent tubing from 10% bleach solution and cycle all the fluid from the syringes and tubing into a waste container.

- 4 Prime the pump a minimum of 10 cycles with distilled or de-ionized water.

## 5.3 Periodic Maintenance

Tubing, syringe seals, and valve connector require periodic maintenance. If they become worn, you are likely to notice these symptoms:

- Poor precision and accuracy
- Variable or moving air gap
- Leakage

If any of these symptoms occurs and it is not obvious which component is causing the problem, it is easiest and most economical to replace one component at a time in the following order:

- input and output tubing
- plunger seal
- valve connector

The frequency of replacement will depend on the duty cycle, fluids used, and instrument maintenance.

### 5.3.1 Quality Control Assurance

Check the accuracy and precision of the SP4-D1 on a regular basis.

It is recommended to check both accuracy and precision gravimetrically, using an analytical balance with the capability to measure to 0.1 mg. Gravimetric measurements should be corrected for the specific gravity of water at the ambient temperature.

The syringe can be checked by programming in the desired volume and determining the weight of fluid dispensed.

To determine precision and accuracy, run a minimum of 20 replicates. The Mean, Standard Deviation and Coefficient of Variation (see formula below) can then be calculated. The calculations to determine accuracy must take into account the specific gravity of water, which is dependent upon temperature. In addition, to prevent a false reading caused by fluid adhering to the tip of the aspirate tubing, a small amount of surfactant should be added to the water (e.g., Fluorad® at a 0.01% concentration)

% Coefficient of Variation= (Standard Deviation/Mean)\*100

$$\%CV = \left( \frac{\sqrt{\frac{1}{n-1} \sum_{i=1}^n (X_i - \bar{X})^2}}{\bar{X}} \right) * 100$$

$$\% Accuracy = \left[ \frac{\left| \frac{\bar{X}}{sg} \right| * 100}{Vol_{expected}} \right] - 100$$

Where:

sg=specific gravity of water @25°C=0.99707

Vol=expected volume to be dispensed

n= number of replicate

$X_i$ = individual result

$\bar{X}$  = mean of all results

### 5.3.2 Replacing Dispense or Reagent Tubing

To replace dispense or reagent tubing, follow these steps:

- 1 Unscrew the fittings, remove the tubing.
- 2 To install new tubing, insert the fitting into the valve connector and tighten it.

Steps to place tubing & fitting assembly:

Step 1: use a wallpaper knife to make a 20-30 slope incision at the end of tubing.

步骤一：先用壁纸刀在所配管路一端切出一个20~30°左右的切口。

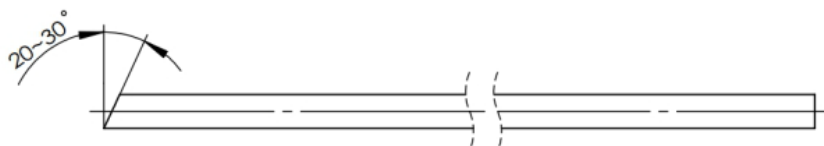

Step 2: thread the fitting and inverted cone to the tubing in the order shown below.

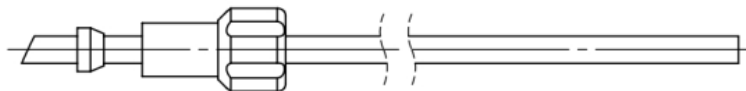

Step 3: use a wallpaper knife to cut the angled incision at the end of the tubing flat.

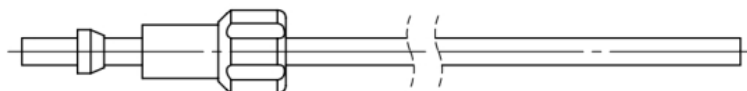

Step 4: thread the tubing, fitting and inverted cone into the valve port.



### 5.3.3 Replacing a Syringe

To replace a syringe, follow these steps:

- 1 Remove as much fluid as possible from the system by cycling the pump and using air as the system fluid.
- 2 Loosen the plunger lock screw approximately four full turns.
- 3 Initialize the pump.
- 4 Lower the plunger drive by sending the command [A1000R].
- 5 Unscrew and remove the syringe.
- 6 To install the syringe (as shown in Figure 5-1)
  - a Pull the syringe plunger down to the plunger holder, and insert the holder into the hole of the plunger.
  - b Put the gasket into the valve connector port, then screw the syringe into the valve connector port.
  - c Tighten the plunger lock screw to ensure the syringe plunger into place.
- 7 Reinitialize the pump.

Note: Make sure the plunger lock screw is securely tightened.

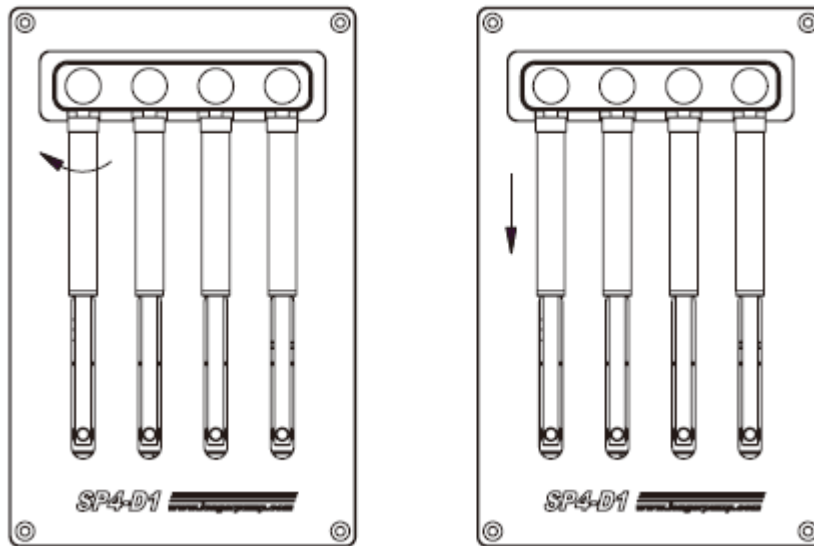

**Figure 5-1 Syringe Replacement**

## 6 Technical Service

For more information or questions about ordering or operating, please contact company through the methods listed below:

Phone: 86-0312-3110087

Fax: 86-0312-3168553

URL: [Http://www.longerpump.com](http://www.longerpump.com)

Mailing address:

Baoding Longer Precision Pump Co., Ltd.

Address: 3rd/4th Floor, Building 6B, University Science Park Baoding National, High - Tech Industrial Development Zone Baoding, Hebei, China 071051

When you call company for technical service, please provide below material:

- Serial Number
- Order Time
- Operating Environment
- Description of the problem

## **Appendix A Plunger Information**

Plunger force: 6.8kgf

Plunger speed: V1-V800, responding to 0.03mm/s-24mm/s (full stroke time from 2000s to 2.5s)

## Appendix B ASCII Chart

Decimal	Hexadecimal	Character or Function	Decimal	Hexadecimal	Character or Function
0	00	none	31	1F	US
1	01	SOH	32	20	SP
2	02	STX	33	21	!
3	03	ETX	34	22	"
4	04	EOT	35	23	#
5	05	ENQ	36	24	\$
6	06	ACK	37	25	%
7	07	BEL	38	26	&
8	08	BS	39	27	'(apostrophe)
9	09	HT	40	28	(
10	0A	LF	41	29	)
11	0B	VT	42	2A	*
12	0C	FF	43	2B	+
13	0D	CR	44	2C	,(comma)
14	0E	SO	45	2D	-(en dash)
15	0F	SI	46	2E	.(Period)
16	10	DLE	47	2F	/
17	11	DC1	48	30	0
18	12	DC2	49	31	1
19	13	DC3	50	32	2
20	14	DC4	51	33	3
21	15	NAK	52	34	4
22	16	SYN	53	35	5
23	17	ETB	54	36	6
24	18	CAN	55	37	7
25	19	EM	56	38	8
26	1A	SUB	57	39	9
27	1B	ESC	58	3A	:
28	1C	FS	59	3B	;
29	1D	GS	60	3C	<
30	1E	RS	61	3D	=
			62	3E	>
			63	3F	?



Decimal	Hexadecimal	Character or Function	Decimal	Hexadecimal	Character or Function
64	40	@	96	60	` (tick)
65	41	A	97	61	a
66	42	B	98	62	b
67	43	C	99	63	c
68	44	D	100	64	d
69	45	E	101	65	e
70	46	F	102	66	f
71	47	G	103	67	g
72	48	H	104	68	h
73	49	I	105	69	i
74	4A	J	106	6A	j
75	4B	K	107	6B	k
76	4C	L	108	6C	l
77	4D	M	109	6D	m
78	4E	N	110	6E	n
79	4F	O	111	6F	o
80	50	P	112	70	p
81	51	Q	113	71	q
82	52	R	114	72	r
83	53	S	115	73	s
84	54	T	116	74	t
85	55	U	117	75	u
86	56	V	118	76	v
87	57	W	119	77	w
88	58	X	120	78	x
89	59	Y	121	79	y
90	5A	Z	122	7A	Z
91	5B	[	123	7B	{ (Left brace)
92	5C	\(backslash)	124	7C	(Vertical bar)
93	5D	]	125	7D	} (Rightbrace)
94	5E	^ (control)	126	7E	~ (Tilde)
95	5F	- (emdash)	127	7F	DEL

## Appendix C Chemical Resistance Chart

Table 7-1, which starts on the following page, provides a summary of chemical compatibility information provided by the manufacturers of components in the SP4-D1 fluid path. LongerPump recommends that you use this information as a guideline only, and that you test each application fluid for chemical compatibility.

Caution: Failure to test chemicals used in individual applications with the SP4-D1 may result in damage to the pump and/or test results.

The materials listed in Table 7-1 are used in the following areas of the SP4-D1:

PTFE	Tubing, Seal, Gasket
PPS	Valve Connector Body
PP	Fitting for Tubing

The codes and symbols in Table 7-1 are as follows:

- No Data
- 0 No effect – excellent
- 1 Minor effect – good
- 2 Moderate effect – fair
- 3 Severe effect – not recommended
- \* PP- 22°C
- \*\* PP- 49°C

**Table 7-1 Chemical Resistance Chart**

Solvent	Teflon	Kel F	Polypropylene
Acetaldehyde	0	0	0
Acetates	-	0	0
Acetic Acid	0	0	0
Acetic Anhydride	-	0	-
Acetone	0	0	0
Acetyl Bromide	0	-	
Ammonia	0	-	0
Ammonium Acetate	0	-	-
Ammonium Hydroxide	0	0	0
Ammonium Phosphate	-	0	0
Ammonium Sulfate	-	0	0
Amyl Acetate	0	-	3
Aniline	0	0	0
Benzene	0	3	*
Benzyl Alcohol	0	0	0
Boric Acid	0	0	0
Bromine	0	0	*
Butyl Alcohol	0	0	1
Butyl Acetate	0	-	*
Carbon Sulfide	0	-	*
Carbon Tetrachloride	0	1	3
Chloroacetic Acid	0	0	-
Chlorine	0	1	3
Chlorobenzene	-	-	3
Chloroform	0	-	3
Chromic Acid	0	0	-
Cresol	0	-	*
Cyclohexane	0	-	3
Ethers	0	-	**
Ethyl Acetate	0	-	0
Ethyl Alcohol	0	-	0
Ethyl Chromide	0	1	3
Formaldehyde	0	0	0

Solvent	Teflon	Kel F	Polypropylene
Formic Acid	0	0	0
Freon	0	2	0
Gasoline	0	0	3
Glycerin	0	0	0
Hydrochloric Acid	0	0	0
Hydrochloric Acid (conc)	0	0	0
Hydrofluoric Acid	0	0	*
Hydrogen Peroxide	0	0	0
Hydrogen Peroxide (conc)	0	0	0
Hydrogen Sulfide	0	0	0
Kerosene	0	0	0
Methyl Ethyl Ketone (MEK)	0	-	0
Methyl Alcohol	0	-	0
Methylene Chloride	0	0	3
Naptha	0	1	0
Nitric Acid	0	0	0
Nitric Acid	0	0	-
Nitrobenzene	0	-	**
Phenol	0	-	0
Pyridine	0	-	-
Silver Nitrate	0	-	0
Soap Solutions	0	-	0
Stearic Acid	0	-	*
Sulfuric Acid	0	0	0
Sulfuric Acid (conc)	0	0	-
Sulfurous Acid	0	0	0
Tannic Acid	0	0	0
Tanning Extracts	-	-	-
Tartaric Acid	0	-	-
Toluene	0	1	**
Trichloroethylene	0	3	3
Turpentine	0	0	**
Water	0	0	0
Xylene	0	0	*

## Appendix D Technical Specification

<b>Plunger</b>		
Principle	Synchronous belt mechanism	
Full Stroke	60mm (1000steps)	
Time for One Stroke	2.5s-2000min	
Linear Speed	60mm/2000s-60mm/2.5s	
Control Resolution	1 step of 0.06mm	
Travel Control Accuracy	error $\leq\pm 1\%$ at full stroke	
Plunger Force	$\geq 6.8\text{kgf}$	
Syringe	50ul 100ul 250ul 500ul 1ml 2.5ml 5ml	
<b>Valve</b>		
Valve Type	2-way valve connector	
Valve Drive	4 Outputs for external solenoid valves control (24VDC, 200mA)	
Valve Connector Material	PPS	
Valve Connector Fitting	Tubing fitting: 1/4-28; Syringe fitting: 1/4-28	
<b>External Interface</b>		
Communication Interface	RS485 interface, 9600bps or 38400bps	
	RS232 interface, 9600bps or 38400bps	
Inputs	2 TTL level inputs; Used to resume the execution after [H] command	
Outputs	3 TTL level outputs	
Device Address Switch	Set the pump address through the Address Switch	
DIP Dial Switch	Set the baud rate, RS232 or RS485, protocol, stalling protection enable.	
<b>Commands</b>		
Initialization Commands	Initialize the plunger	
Set Commands	Set the speed, backlash steps.	
Valve Command	Energize or de-energize the external solenoid valve	
Plunger Movement Command	Move plunger to desired position	
Report Commands	Monitor plunger position, plunger speed and other status.	
<b>Outline Dimension</b>	Height	260mm
	Width	167mm
	Depth	140mm
<b>Power Supply</b>	Power Voltage	24V DC
	Max Current	$\leq 1.5\text{ A}$
<b>Operating Environment</b>	Temperature	15°C-40°C
	Humidity	20-95% @ 40°C

## Appendix E SP4-D1 Command Quick Reference

### Control Commands (for operating and execution)

Command	Parameter<n>	Default	Parameter Description	Command Description
R	-	-	-	Executes the command immediately
X	-	-	-	Executes the last executed command
G<n>	0~30000	1	0=endless loop; 1~30000=repeat number	Repeats command sequence
g	-	-	-	Marks the start of a repeat sequence
M<n>	5~30000	-	Delay time 5~30000ms	Delays the execution of a command
H<n>	0~2	0	0= Waits for [R] or rising edge of either input 1 or 2 to resume the execution, 1= Waits for [R] or rising edge of input 1 to resume the execution, 2= Waits for [R] or rising edge of input 2 to resume the execution	Halts command execution
T	-	-	Terminates the command (string)	Terminates command execution
J<n>	0~7	0	0: Three outputs are low level; 1: Output 1 is high, others are low 2: Output 2 is high, others are low 3: Output 3 is low, others are high 4: Output 3 is high, others are low 5: Output 2 is low, others are high 6: Output 1 is low ,others are high 7: Three outputs are high level;	Output control command
h				Plunger will stop when receives this command.
r		-		Continue the command (string) stopped by [h] command.

## Initialization Commands

Command	Parameter<n>	Default	Parameter Description	Command Description
Z<n>	0~7	0	Initialize the plunger at speed code <n>. 0 means V800, 1-7 means V100-V700	Initialize the plunger to "home" position

## Plunger Movement Commands

Command	Parameter<n>	Default	Parameter Description	Command Description
A<n>	0~1000	0	The number of absolute position	Moves plunger to the absolute position
P<n>	1~1000	1	The number of steps	Moves the plunger down the number of steps
D<n>	1~1000	1	The number of steps	Moves the plunger up the number of steps
p			Quick Rinse	The plunger will move twice in full stroke

## Valve Commands

Command	Parameter <n>	Default	Parameter Description	Command Description
I<n>	0-8	0	0: Energize 4 solenoid valves 1: Energize valve 1 2: Energize valve 2 3: Energize valve 3 4: Energize valve 4 5: Energize valve1 and 2 6: Energize valve 2 and 3 7: Energize valve 3 and 4 8: Energize valve 1 and 4	Energize the external solenoid valves by outputting 24VDC voltage
O<n>	0-8	0	0: De-energize 4 solenoid valves 1: De-energize valve 1 2: De-energize valve 2 3: De-energize valve 3 4: De-energize valve 4 5: De-energize valve1 and 2 6: De-energize valve 2 and 3 7: De-energize valve 3 and 4 8: De-energize valve 1 and 4	De-energize the external solenoid valves by no voltage output

## Set Commands

Command	Parameter<n>	Default	Parameter Description	Command Description
K<n>	0~50	30	Number of backlash steps	Sets number of backlash steps
V<n>	1~800		Set the plunger speed $V = 60\text{mm} \cdot n / 2000\text{s}$	Set plunger speed



## Report Commands

Command	Return Parameter	Parameter Description	Command Description
Q	Status Byte		Reports pump status and error codes
?		Absolute plunger position	Reports absolute target position of the plunger
?V		Plunger speed	Report plunger speed
F		Command buffer status: 0= empty; 1= commands in buffer;	Report command buffer status
?K		Backlash steps	Report number of backlash steps
?J		Status of output	Report status of Auxiliary output
?I		Status of input	Report status of Auxiliary input

## Error Codes

Error Code	Description
0(00h)	Error Free Condition.
1(01h)	Initialization error. This error occurs when the pump fails to initialize.
2(02h)	Invalid Command. This error occurs when an unrecognized command is issued. Correct the command and operation will continue normally.
3(03h)	Invalid Parameter. This error occurs when an invalid parameter <n> is given with a command. Correct the parameter and pump operation will continue normally.
4(04h)	Invalid Command String. This error occurs when invalid command string is received.
5(05h)	Reserved.
6(06h)	Reserved.
7(07h)	Device Not Initialized. This error occurs when the pump is not initialized. To clear the error, initialize the pump.
9(09h)	Plunger Overload. This error occurs when movement of the syringe plunger is blocked by excessive backpressure. The pump must be reinitialized before normal operation can resume. This error can only be cleared by reinitializing

	the pump.
10(0Ah)	Reserved.
11(0Bh)	Reserved.
15(0Fh)	Reserved.

## Error Code and Pump Status

Status Byte	Hex # if Bit 5 =		Dec # if Bit 5 =		Error Code	Error description
	0	or 1	0	or 1	Number	
7 6 5 4 3 2 1 0	0	or 1	0	or 1	Number	Error description
0 1 X 0 0 0 0 0	40h	60h	64	96	0	No Error
0 1 X 0 0 0 0 1	41h	61h	65	97	1	Initialization Error
0 1 X 0 0 0 1 0	42h	62h	66	98	2	Invalid Command
0 1 X 0 0 0 1 1	43h	63h	67	99	3	Invalid Parameter
0 1 X 0 0 1 0 0	44h	64h	68	100	4	Invalid Command String
0 1 X 0 0 1 0 1	45h	65h	69	101	5	Reserved
0 1 X 0 0 1 1 0	46h	66h	70	102	6	Reserved
0 1 X 0 0 1 1 1	47h	67h	71	103	7	Device Not Initialized
0 1 X 0 1 0 0 1	49h	69h	73	105	9	Plunger Overload
0 1 X 0 1 0 1 0	4Ah	6Ah	74	106	10	Reserved
0 1 X 0 1 0 1 1	4Bh	6Bh	75	107	11	Reserved
0 1 X 0 1 1 1 1	4Fh	6Fh	79	111	15	Reserved

## DB-15 Pin Definition

Pin	Function	Remarks
1	DC_24V	Power Supply+
2	TXD	RS232 Output data
3	RXD	RS232 Input data
4	COM	Logic ground for input and output
5	NC	Reserved
6	NC	Reserved
7	IN1	Input 1
8	IN2	Input 2

9	GND	Power and logic
10	GND	Power and logic
11	RS-485 A	RS-485 A
12	RS-485 B	RS-485 B
13	OUT1	Output 1
14	OUT2	Output 2
15	OUT3	Output 3

## DIP Dial Switch Setting

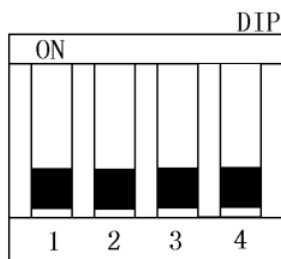

DIP	Definition	ON	OFF
1	Protocol	Data Terminal (DT) protocol	OEM protocol
2	Baud Rate	38400 bps	9600 bps
3	Communication Interface	RS232	RS485
4	Stalling protection	Disable	Enable